

USER MANUAL

UMAC MACRO & MACRO STACK

3U Remote Interface

3Ax-602804-xUxx

January 29, 2003



Single Source Machine Control

Power // Flexibility // Ease of Use

21314 Lassen Street Chatsworth, CA 91311 // Tel. (818) 998-2095 Fax. (818) 998-7807 // www.deltatau.com

Copyright Information

© 2003 Delta Tau Data Systems, Inc. All rights reserved.

This document is furnished for the customers of Delta Tau Data Systems, Inc. Other uses are unauthorized without written permission of Delta Tau Data Systems, Inc. Information contained in this manual may be updated from time-to-time due to product improvements, etc., and may not conform in every respect to former issues.

To report errors or inconsistencies, call or email:

Delta Tau Data Systems, Inc. Technical Support

Phone: (818) 717-5656

Fax: (818) 998-7807

Email: support@deltatau.com

Website: <http://www.deltatau.com>

Operating Conditions

All Delta Tau Data Systems, Inc. motion controller products, accessories, and amplifiers contain static sensitive components that can be damaged by incorrect handling. When installing or handling Delta Tau Data Systems, Inc. products, avoid contact with highly insulated materials. Only qualified personnel should be allowed to handle this equipment.

In the case of industrial applications, we expect our products to be protected from hazardous or conductive materials and/or environments that could cause harm to the controller by damaging components or causing electrical shorts. When our products are used in an industrial environment, install them into an industrial electrical cabinet or industrial PC to protect them from excessive or corrosive moisture, abnormal ambient temperatures, and conductive materials. If Delta Tau Data Systems, Inc. products are exposed to hazardous or conductive materials and/or environments, we cannot guarantee their operation.

TABLE OF CONTENTS

INTRODUCTION	1
3U MACRO STATION SETUP OVERVIEW	3
3U MACRO STATION HARDWARE SETUP	7
Physical and Logical Configuration of the MACRO Station	7
Stack Configuration.....	7
UMAC (Pack) Configuration.....	8
Hybrid Stack/Pack Interface Configurations.....	9
Wiring into the MACRO Station	10
Stack Interface and Breakout Boards.....	10
UMAC (Pack) Interface/Breakout Boards.....	11
MACRO CPU SW1 Setting	12
MACRO CPU SW2 Setting	13
PMAC2 SOFTWARE SETUP FOR MACRO STATION	15
MACRO Ring Update Frequency Setup	15
PMAC2 Ultralite: 1992 and 1997.....	15
PMAC2 (Not Ultralite): 1900 and 1901	15
Notes on Servo Clock.....	16
PMAC2 MACRO Ring Setup I-Variables	16
1995: MACRO Master & Ring Controller Enable.....	16
1996: MACRO Node Activation Control.....	16
11000: MACRO Node Auxiliary Function Enable.....	17
11002: MACRO Node Protocol Type Control	17
11001, 11004, 11005: MACRO Ring Check Period and Limits	18
11003: MACRO Master/Slave Auxiliary Timeout	18
MACRO Node Addresses	18
PMAC2 Conversion Table Setup.....	19
PMAC2 Motor I-Variables.....	21
Ix02: Command Output Address	21
Ix03, Ix04: Feedback Address	22
Ix10: Power-On Feedback Address.....	22
Ix25: Flag Address	23
Ix70, Ix71: Commutation Cycle Size.....	24
Ix75: Absolute Phase Position Offset	24
Ix81: Power-On Phase Position Address	25
Ix82: Current Loop Feedback Address.....	26
Ix83: Commutation Feedback Address.....	26
TURBO PMAC2 SOFTWARE SETUP FOR MACRO STATION	27
MACRO IC Address Specification	27
MACRO Ring Update Frequency Setup	27
17: Phase Cycle Extension.....	27
119: Clock Source I-Variable Number.....	28
Turbo PMAC2 Ultralite: 16800 and 16801	28
Turbo PMAC2 (Not Ultralite): 17000 and 17001.....	29
UMAC Turbo.....	29
Notes on Servo Clock.....	29
Turbo PMAC2 MACRO Ring Setup I-Variables	30
16840: MACRO IC 0 Master Configuration	30
16890/16940/16990: MACRO IC 1/2/3 Master Configuration	30
16841/16891/16941/16991: MACRO IC 0/1/2/3 Node Activation Control	30
170/172/174/176: MACRO IC 0/1/2/3 Node Auxiliary Function Enable.....	31
171/173/175/177: MACRO IC 0/1/2/3 Node Protocol Type Control.....	32
178: MACRO Master/Slave Auxiliary Communications Timeout	32

179: MACRO Master/Master Auxiliary Communications Timeout	32
180, 181, 182: MACRO Ring Check Period and Limits	33
MACRO Node Addresses	33
Turbo PMAC2 Conversion Table Setup	36
Turbo PMAC2 Motor I-Variables	38
Ixx01: Commutation Enable	38
Ixx02: Command Output Address	38
Ixx03, Ixx04: Feedback Address	39
Ixx10, Ixx95: Absolute Position Address and Format	40
Ixx25, Ixx24: Flag Address and Mode	42
Ixx70, Ixx71: Commutation Cycle Size	43
Ixx75: Absolute Phase Position Offset	43
Ixx81, Ixx91: Power-On Phase Position Address and Mode	44
Ixx82: Current Loop Feedback Address	45
Ixx83: Commutation Feedback Address	46
SOFTWARE SETUP OF 3U MACRO STATION	47
Station Variable Read/Write Commands	47
Station Variable Copy Commands	48
Ring Control Setup Variables	48
Additional Node Enabling & Disabling	49
Multi-channel Servo Interface Setup	50
Channels 1-4 (1 st 4-Axis Board)	50
Channels 5-8 (2 nd 4-Axis Board)	51
Single-Channel Servo Interface Channel Setup	53
Station Encoder Conversion Table Setup	54
Amplifier Fault Enable and Polarity Control	61
Servo Address Variable Setup	62
General-Purpose I/O Setup	63
MI975 I/O Node Enable	63
MI19 I/O Transfer Period	63
Bi-directional I/O Transfer Control	63
Uni-directional I/O Transfer Control	67
Macro Station Position Capture Setup	68
Setting the Trigger Condition	68
Using for Homing	68
Using in User Program	69
APPENDIX: MACRO STATION TYPE 1 PROTOCOLS	71
Velocity/Torque Mode	71
Phase Current (“Sinewave”) Mode	71
Phase Voltage (“Direct PWM”) Mode	71

INTRODUCTION

The 3U MACRO Station, in either MACRO Stack or UMAC MACRO (pack) form, provides a remote interface for encoders, flags, direct-PWM digital drives, analog drives, and/or digital I/O for a PMAC2 or Turbo PMAC2 with MACRO interface. It communicates with PMAC2 solely through the MACRO ring, but interfaces to standard drives, encoders, flags, and Opto-22 style I/O through on-board connectors.

With the fiber optic MACRO interface, the 3U MACRO Station can be up to 3 kilometers (2 miles) away from the PMAC2 controller or any other station on the ring. With the RJ-45 electrical interface, it can be up to 30 meters (100 feet) away.

With the 3U MACRO Station, PMAC2 can control servo axes and I/O just as if they were directly connected to the PMAC2, even though they are a great distance away, and the only interface from the PMAC2 is the MACRO ring.

Typically, a PMAC2 “Ultralite” board, one without any of its own servo interface circuitry, is used with the 3U MACRO Station to provide the most cost-effective solution.

This manual will walk you through the setup of the 3U MACRO Station. It is designed to be used in conjunction with the Hardware Reference manuals for the 3U MACRO CPU board and the 3U-format accessories that are used, and the Software Reference Manual for the MACRO Station.

3U MACRO STATION SETUP OVERVIEW

Fundamentally, the setup of the 3U MACRO Station with a PMAC2 or Turbo PMAC2 (usually an “Ultralite” version) involves several steps of “mapping” registers and connections.

For the axis control, the following mappings must occur:

1. The first mapping is the connection of physical devices (encoders, drives, and flags) to a particular machine interface channel on the MACRO Station.
2. The second mapping is between the servo interface channel and a MACRO node on the Station.
3. The third mapping is between the MACRO node of the Station and a MACRO node on the PMAC2.
4. The fourth mapping is between the MACRO node on the PMAC2 and the motor calculation registers.

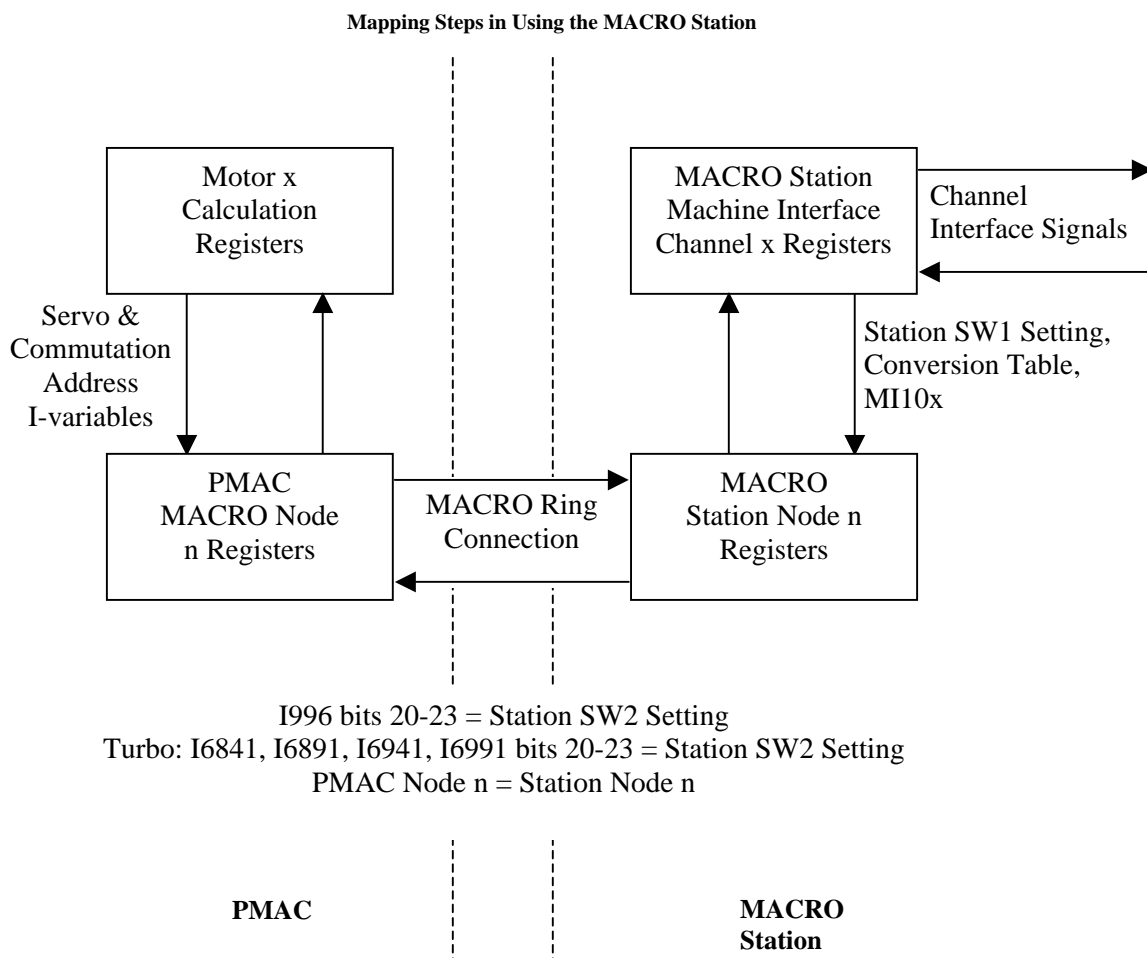

Once the basic mapping is set up, the operation of the MACRO ring becomes essentially invisible to the actual operation of the system, and the system operates just as if devices were directly interfaced to the MACRO controller.

This section summarizes the steps that control the mapping of the motion control functions. All of these items are covered in more detail in following sections:

1. Mapping physical devices to the 3U MACRO Station’s machine interface channels:

- Station node-specific variables MI910 - MI939 configure hardware for the machine interface channels associated with specified MACRO node by SW1
 - For stack axis-interface boards, appropriate ACC-8x breakout boards or equivalent for Station JMACH connectors provide easy wiring interface to external devices.
 - For UMAC (“pack”) axis-interface boards, breakout connectors are integral to the boards.
 - Wiring between breakout connectors and external devices provides physical connection.
2. Mapping the 3U MACRO Station’s machine interface channels to the Station’s MACRO motor node registers:

- Station SW1 switch setting controls mapping of output commands and flags between machine interface channels and nodes
- Station Encoder conversion table (MI120-MI151) and Motor x variables MI10x control mapping of feedback position from machine interface channels to Station MACRO nodes
- Station Motor x variables MI11x control mapping of power-on absolute feedback position to Station MACRO nodes

Mapping Machine Interface Channels to MACRO Nodes

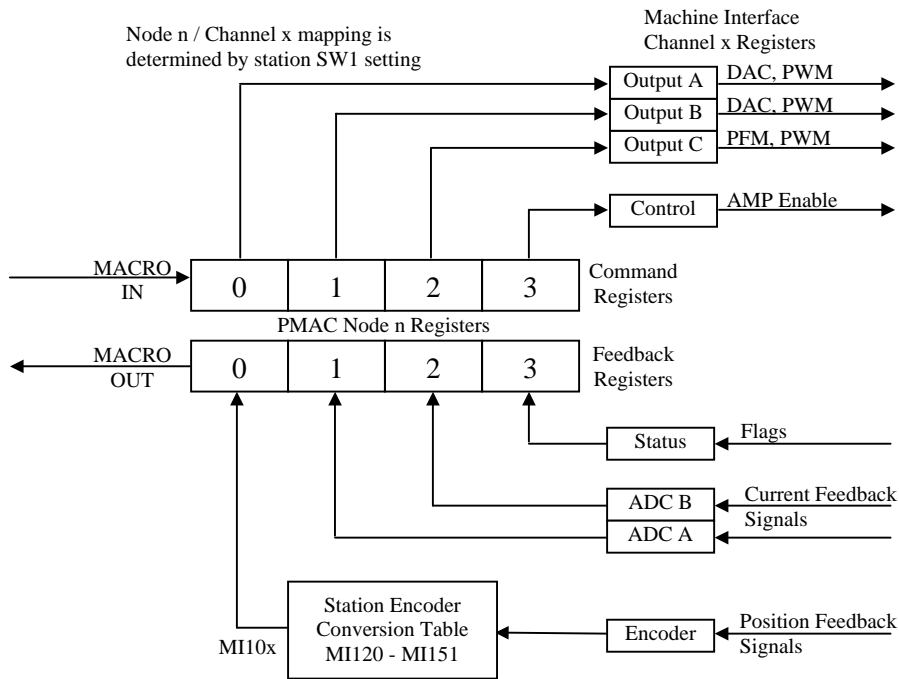

3. Mapping the 3U MACRO Station’s MACRO motor node registers to the PMAC2’s [Turbo PMAC2’s] MACRO motor node registers

- Connection of the PMAC2 and MACRO Station in a common ring
- PMAC2 MACRO cycle frequency control
- PMAC2 Ultralite I992 and I997 [Turbo:I6800, I6801]
- PMAC2 (non-Ultralite) I900 and I901 [Turbo I7000, I7001, or I7200, I7201]
- PMAC2 I995 MACRO Master Type [Turbo: I6840, I6890, I6940, I6990]

- PMAC2 I996 MACRO Node Activation Control & Master number [Turbo: I6841, I6891, I6941, I6991]
- PMAC2 MACRO Configuration I-variables
- I1000 MACRO Node Auxiliary Register Enable [Turbo: I70, I72, I74, I76]
- I1001 MACRO Ring Check Period [Turbo: I80]
- I1002 MACRO Node Type Control [Turbo: I71, I73, I75, I77]
- I1003 MACRO Type 1 Master/Slave Auxiliary Timeout [Turbo: I79]
- I1004 MACRO Maximum Ring Error Count [Turbo: I81]
- I1005 MACRO Minimum Sync Packet Count [Turbo: I82]
- Station SW2 setting for Master number
- Station SW1 setting and MI976 setting for active MACRO servo nodes
- Station MACRO cycle frequency control with MI992 and MI997

Mapping between PMAC and MACRO Station Nodes
 MACRO hardware automatically copies every phase cycle

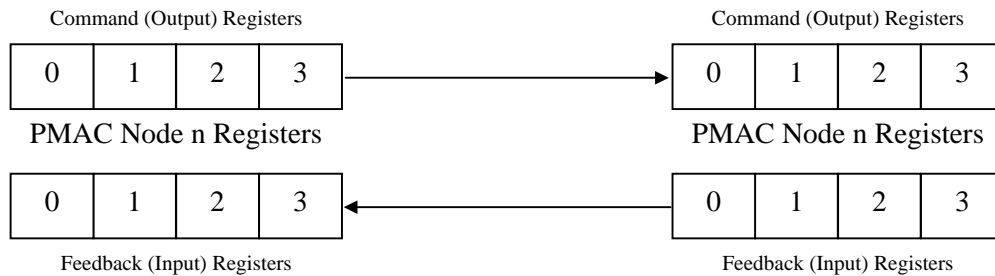

PMAC Node Master Number
 set by I996 bits 20-23
 Turbo PMAC Node Master Number set
 by I6841, I6891, I6941, I6991 bits 20-23

Station Node Master
 Number set by SW2

Node Slave Number n automatically matches between
 PMAC and MACRO Station

4. Mapping the PMAC2 [Turbo PMAC2] motor function registers to the PMAC2 MACRO node registers

- PMAC Encoder Conversion Table Setup Addresses [Turbo: I8000 – I8191]
- Ix02 Command Output Address [Turbo: Ixx02]
- Ix03 Position-Loop Feedback Address [Turbo: Ixx03]
- Ix04 Velocity-Loop Feedback Address [Turbo: Ixx04]
- Ix10 Power-On Position Feedback Address [Turbo: Ixx10, Ixx95]
- Ix25 Flag Address [Turbo: Ixx25, Ixx24]
- Ix81 Power-On Phase Feedback Address [Turbo: Ixx81, Ixx91]
- Ix82 Current-Loop Feedback Address [Turbo: Ixx82]

- Ix83 Phase Position Feedback Address [Turbo: Ixx83]

Mapping Between MACRO Node and Motor Calculation Registers

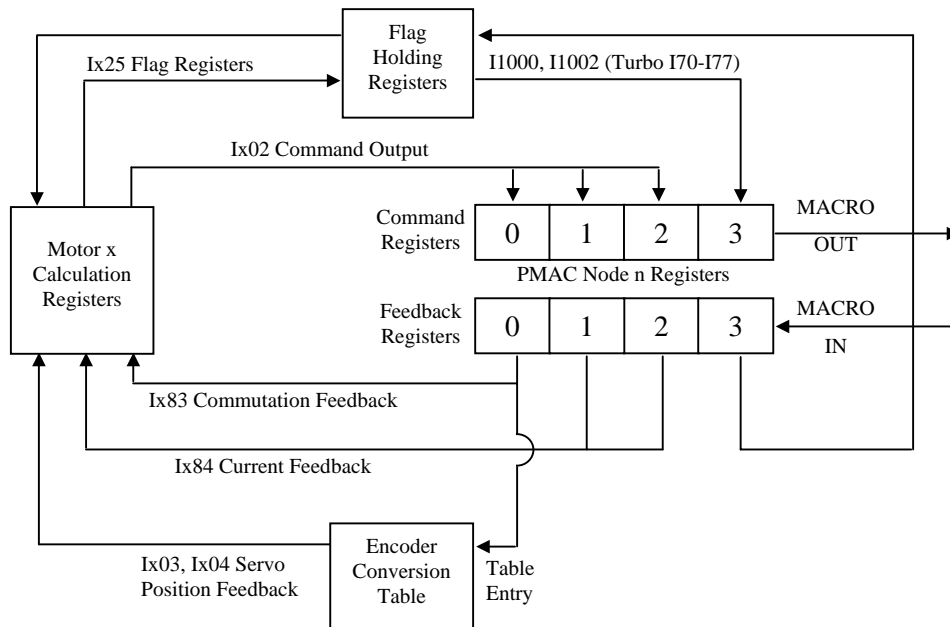

General-purpose I/O is processed through a similar set of mapping functions. Once the setup of the mapping has been done, PMAC software can access the I/O points on the 3U MACRO Station as if they were on the PMAC itself.

- Mapping physical devices to the 3U MACRO Station I/O circuitry
- Wiring between the I/O connectors and the devices
- Mapping the Station I/O registers to 3U MACRO Station MACRO I/O nodes
- Station MI19 setting for frequency of data copying
- Station MI69 – MI71, MI169 – MI175 settings for matching MACRO I/O nodes to accessory boards with “IOGATE” ICs: ACC-3E/4E “stack” I/O boards, ACC-9E – 12E, 14E UMAC I/O boards.
- Station MI20-MI68 settings for matching MACRO I/O nodes to other I/O circuitry, e.g. ACC 1E/6E stack ADC boards, ACC-36E/59E ADC/DAC boards
- Mapping 3U MACRO Station MACRO I/O nodes to PMAC MACRO I/O nodes
- Connection of the PMAC and MACRO Station in a common ring
- PMAC2 I996 MACRO Node Activation Control of MACRO I/O Nodes [Turbo: I6841, I6891, I6941, I6991]
- Station SW2 setting for Master number
- Station MI975 setting for active MACRO I/O nodes
- Mapping PMAC MACRO I/O nodes to PMAC M-variables
- M-variable definitions to “images” of I/O in PMAC memory
- M-variable definitions to MACRO node registers (entire register only)
- PMAC commands (usually in PLC) to copy between image registers and MACRO I/O nodes

3U MACRO STATION HARDWARE SETUP

The hardware setup of the 3U MACRO Station, in either UMAC MACRO or MACRO Stack configurations, is covered in the Hardware Reference manual for the 3U MACRO CPU Board, and the manuals for each of the individual accessory boards in the Station. Refer to these manuals for details. A brief summary is given here.

The electronic hardware of a 3U MACRO Station consists of a 3U MACRO CPU/Interface board that contains the MACRO link to the ring and the processor that governs the operation of the Station, plus some combination of axis interface boards and I/O interface boards.

Physical and Logical Configuration of the MACRO Station

This section briefly describes how the boards in a MACRO Station physically fit together and how they communicate – what addresses they occupy in the address space of the MACRO CPU. More details are given in the manuals for each specific board.

Stack Configuration

In the “Stack” configuration, the axis-interface boards and the I/O-interface boards “piggyback” on top of the MACRO CPU board. They are physically held together by the connectors and by standoffs in each corner that hold the boards 20.32 mm (0.8”) apart (on center). The resulting board stack can be installed in a standard 3U-format rack with “4T” board spacing. The physical order of the boards on top of the MACRO CPU board does not matter.

Servo Interface Boards

For servo interface, the MACRO CPU board can address up to two ACC-2E 4-axis servo interface boards and one ACC-1E 2-axis interface boards. The numbering of the machine interface channels on these boards is as follows:

Axis Interface Board	Jumper Setting	Channels	Board Base Address
ACC-2E	E1: 1 & 2	1, 2, 3, & 4	\$C000
ACC-2E	E1: 2 & 3	5, 6, 7, & 8	\$C040
ACC-1E	--	9 & 10	\$C090

I/O Interface Boards

For digital I/O, the MACRO CPU board can address up to a total of four ACC-3E TTL-I/O boards and ACC-4E Isolated I/O boards. Each must be at a unique address in the MACRO CPU’s address space. The following table shows the four possible base addresses:

ACC-3E/4E Address Jumper	Board Base Address
E1*	\$FFC0*
E2	\$FFC8
E3	\$FFD0
E4	\$FFD8
*Cannot be used if ACC-1E/6E A/D converters are present	

For analog inputs, the MACRO CPU can address only one ACC-6E A/D-converter board or Option B of the ACC-1E 2-axis board. The base address of this A/D-converter bank is \$FFC0; if the A/D converter bank is installed, no digital I/O board may also be installed at this address.

UMAC (Pack) Configuration

In the UMAC (“Pack”) configuration, the axis-interface boards and the I/O-interface boards communicate to the MACRO CPU board via an ACC-Ux “UBUS” backplane board. Each board can slide into a standard 3U rack with “4T” (20mm, 0.8”) spacing between boards and physically connect to the backplane board.

Servo Accessory Boards

For servo interface, the MACRO CPU board can address up to two servo interface/breakout accessory boards on the backplane. The boards in this family that are presently available include:

- ACC-24E2 2/4-Channel PWM Servo Interface/Breakout Board
- ACC-24E2A 2/4-Channel Analog Servo Interface/Breakout Board
- ACC-24E2S 4-Channel Stepper/Encoder Interface/Breakout Board
- ACC-51E High-Resolution Encoder-Interpolator Board

Note:

Option 1A or Option 1D on the ACC-24E2 or ACC-24E2A, while it adds an extra physical slot, does not count as an extra accessory board for addressing purposes.

The addresses and channel numbers on these boards are set by DIP-switch S1 on the board

S1-1	S1-2*	S1-3	S1-4	S1-5	S1-6	Channels	Board Base Address
ON	ON	OFF	OFF	OFF	OFF	1, 2, 3, & 4	\$C040
OFF	OFF	OFF	OFF	OFF	OFF	5, 6, 7, & 8	\$C060
*Always set OFF when interfacing to “legacy” MACRO CPU boards (revision –104 and older of the 602804-10x 3U MACRO CPU board)							

I/O Accessory Boards

For I/O interface, the MACRO CPU board can address accessory boards at four different addresses on the backplane. The addresses on these boards are set by jumpers on some accessory boards, and DIP-switches on other boards

The I/O boards whose addresses are set by jumpers are:

- ACC-9E Isolated 48-Input Board
- ACC-10E Isolated 48-Output Board
- ACC-11E Isolated 24-In/24-Out Board
- ACC-12E Isolated 24-In/24-High-Power-Out Board

For these boards, the jumper settings and the board addresses they select are:

Jumper-Set Addresses

Address Jumper On	Board Base Address
E1	\$FFE0
E2	\$FFE8
E3	\$FFF0
E4*	\$B8C0*
*Requires V1.115 or newer firmware	

For these boards, up to three boards can share an address, because each board only occupies one byte (8 bits) of the 24-bit data bus, and each board can be set up as to which byte it occupies:

E6A- H Rows Connected	Byte Used on Data Bus
1 & 2	Low (Bits 0 – 7)
2 & 3	Middle (Bits 8 – 15)
3 & 4	Middle (Bits 8 – 15)
4 & 5	High (Bits 16 – 23)

The I/O boards presently available whose addresses are set by DIP-switches are:

- ACC-14E 48-TTL-I/O Board
- ACC-28E 2/4-Channel 16-Bit ADC Board
- ACC-36E 16-Channel 12-Bit ADC Board (V1.115 or newer firmware required)
- ACC-53E SSI Encoder Interface Board
- ACC-59E 8-Chan 12-Bit ADC/8-Chan 12-Bit DAC Board (V1.115 or newer firmware required)
- ACC-65E Self-Protected Sourcing 24-In/24-Out Board
- ACC-66E Self-Protected Sourcing 48-Input Board
- ACC-67E Self-Protected Sourcing 48-Output Board
- ACC-68E Self-Protected Sinking 24-In/24-Out Board

For these boards, the switch settings and the board addresses they select are:

S1-1	S1-2	S1-3	S1-4	S1-5	S1-6	Board Base Address
ON	ON	OFF	OFF	OFF	OFF	\$FFE0
OFF	ON	OFF	OFF	OFF	OFF	\$FFE8
ON	OFF	OFF	OFF	OFF	OFF	\$FFF0
OFF	OFF	OFF	OFF	OFF	OFF	\$B8C0*

*Requires V1.115 or newer firmware

With these boards, it is generally only possible to put one board at any given address. (The ACC-14E board always occupies the low byte only of the data bus, so it is possible to put ACC-9E, 10E, 11E, or 12E boards at the same address in the middle or high bytes.)

Hybrid Stack/Pack Interface Configurations

It is possible, although rare, to use both “stack” and “pack” interface boards with a MACRO CPU. There are several special considerations, however. On “stack” boards, the 96-pin “P1” connector is for field wiring, not for the “UBUS” backplane bus. If a P1 field-wiring connector is inserted into the UBUS backplane, the system will not operate at all, and there can be possible damage to any board in the system.

To configure this kind of hybrid system, you must use an ACC-Jx backplane board without an integrated power supply connection. The MACRO CPU board must be installed in the rightmost connector. In this configuration, the interface boards that stack on the MACRO CPU board mount to the right of the backplane board so there is no conflict with their P1 connectors. The power supply, whether mounted in the rack or not, must be connected to the ACC-Jx backplane at screw points.

In addition, even though the logical addressing scheme of the MACRO CPU supports two Servo ASICs on the stack and two more on the backplane, the Station firmware only supports automatic servo transfers and set-up variable support for a total of two Servo ASICs. If the MACRO CPU finds both stack and backplane axis-interface boards set up for the same group of channels (1 – 4 or 5 – 8), it will assign the firmware support to the stack board. If a board does not have the firmware support, the set-up must be accomplished through direct write actions, usually with MI198 and MI199. The regular copying of data for these channels must be done with “I/O” functions, usually MI21 – MI68.

Wiring into the MACRO Station

The connections detailed in the Hardware Reference manuals establish the first mapping required, between the physical devices and the machine interface channels on the MACRO Station. If the Stack configuration is used, the wiring is typically made into an ACC-8x or equivalent breakout board, which is connected to the matching interface board by a short flat cable. If the UMAC “pack” configuration is used, the interface circuitry and breakout connectors are on the same rack-mounted boards, and the field wiring is made directly into these boards.

Stack Interface and Breakout Boards

The Stack boards that are presently available for the MACRO CPU board are:

- ACC-1E 2-Axis Interface Board (limit 1)
- ACC-2E 4-Axis Interface Board (limit 2)
- ACC-3E 48/96/144 TTL I/O Board
- ACC-4E 24-In/24-Out Isolated I/O Board
- ACC-6E 8/16-Channel 12-Bit ADC Board

The 2-axis breakout boards presently available for the ACC-1E and ACC-2E boards through their 100-pin PMAC2-style connectors are:

- ACC-8A Single/Dual Analog Breakout Board (with optional 256x interpolators), DIN-rail mountable
- ACC-8DE Single Analog Breakout Board (with optional 256x interpolators), 3U-rack mountable
- ACC-8E Dual Analog Breakout Board, DIN-rail mountable
- ACC-8F PWM Breakout Board, DIN-rail mountable
- ACC-8FE PWM Breakout Board (with optional 256x interpolators), 3U-rack mountable
- ACC-8FP PWM Breakout Board, panel mountable
- ACC-8K1 Fanuc C/S-Series Breakout Board
- ACC-8S Stepper Breakout Board, DIN-rail mountable

The breakout boards supporting up to 4 axes presently available for the ACC-1E and ACC-2E boards through their 96-pin PMAC(1)-style DIN connectors (provided only with Option A on the 1E and 2E) are:

- ACC-8D 64-Point Terminal Block Board with IDC headers, DIN-rail mountable
- ACC-8DCE Fully Shielded Breakout Board with D-sub connectors, DIN-rail mountable
- ACC-8DP Fully Shielded Breakout Board with D-sub connectors, panel mountable
- ACC-8P 60-Point Terminal Block Board, DIN-rail mountable

The ACC-3E, ACC-4E, and ACC-6E stack boards have IDC headers. Standard breakout boards from sources such as Phoenix Contact can be used for these connectors.

Consult the manuals for each of these accessories for detailed pin-out information.

UMAC (Pack) Interface/Breakout Boards

The UMAC boards presently available that interface to the MACRO CPU board through the UBUS backplane include:

- ACC-24E2 2/4-Channel PWM Servo Interface/Breakout Board
- ACC-24E2A 2/4-Channel Analog Servo Interface/Breakout Board
- ACC-24E2S 4-Channel Stepper/Encoder Interface/Breakout Board
- ACC-51E High-Resolution Encoder-Interpolator Board
- ACC-9E Isolated 48-Input Board
- ACC-10E Isolated 48-Output Board
- ACC-11E Isolated 24-In/24-Out Board
- ACC-12E Isolated 24-In/24-High-Power-Out Board
- ACC-14E 48-TTL-Output Board
- ACC-28E 2/4-Channel 16-Bit ADC Board
- ACC-36E 16-Channel 12-Bit ADC Board (V1.115 or newer firmware required)
- ACC-53E SSI Encoder Interface Board
- ACC-59E 8-Chan 12-Bit ADC/8-Chan 12-Bit DAC Board (V1.115 or newer firmware required)
- ACC-65E Self-Protected Sourcing 24-In/24-Out Board
- ACC-66E Self-Protected Sourcing 48-Input Board
- ACC-67E Self-Protected Sourcing 48-Output Board
- ACC-68E Self-Protected Sinking 24-In/24-Out Board

All of these boards provide their own breakout connectors, so no additional breakout boards are required for the field wiring. Consult the manual for each of these accessory boards for detailed pin-out information.

MACRO CPU SW1 Setting

SW1 establishes how many servo nodes, and which servo nodes, will be used by default on the MACRO station. It also establishes the mapping of MACRO node numbers to MACRO Station channel numbers – the second mapping step explained in the overview. This mapping information will be important in establishing the software setup. The following table shows the possible configurations and the SW1 settings to achieve them.

# of Servo Chan's & Nodes Used	Which MACRO Nodes Used	Station Servo Channel Numbers Used	Stack Axis Boards Used	Station Servo Channel Starting Addresses for Stack Boards	UMAC ("Pack") Axis Boards Used	Station Servo Channel Starting Addresses for UMAC (Pack) Boards	SW1 Setting
0	--	--	--	--	--	--	E(14)
0	--	--	--	--	--	--	F(15) ***
2	0, 1	9, 10	ACC-1E	\$C090, \$C098	--	--	8
2	4, 5	9, 10	ACC-1E	\$C090, \$C098	--	--	9
2	8, 9	9, 10	ACC-1E	\$C090, \$C098	--	--	A(10)
2	12, 13	9, 10	ACC-1E	\$C090, \$C098	--	--	B(11)
2	0, 1	1, 2	ACC-2E	\$C000, \$C008	ACC-24E2x	\$C040, \$C048	2
2	4, 5	3, 4 (Stack) 1, 2* (UMAC)	ACC-2E	\$C010, \$C018	ACC-24E2x	\$C040, \$C048 *	3
2	8, 9	1, 2	ACC-2E	\$C000, \$C008	ACC-24E2x	\$C040, \$C048	4
2	12, 13	3, 4 (Stack) 1, 2* (UMAC)	ACC-2E	\$C010, \$C018	ACC-24E2x	\$C040, \$C048 *	5
4	0, 1, 4, 5	1, 2, 3, 4	ACC-2E	\$C000, \$C008, \$C010, \$C018	ACC-24E2x w/Opt 1x**	\$C040, \$C048, \$C050, \$C058	0
4	8, 9, 12, 13	1, 2, 3, 4	ACC-2E	\$C000, \$C008, \$C010, \$C018	ACC-24E2x w/Opt 1x**	\$C040, \$C048, \$C050, \$C058	1
6	0, 1, 4, 5, 8, 9	1, 2, 3, 4, 9, 10	ACC-1E ACC-2E	\$C000, \$C008, \$C010, \$C018, \$C090, \$C098	ACC-24E2x w/Opt 1x**, ACC-24E2x	--	C(12)

6	0, 1, 4, 5, 8, 9	1, 2, 3, 4, 5, 6	ACC-2E ACC-2E	\$C000, \$C008, \$C010, \$C018, \$C020, \$C028	ACC-24E2x w/Opt 1x**, ACC-24E2x	\$C040, \$C048, \$C050, \$C058, \$C060, \$C068	6
8	0, 1, 4, 5, 8, 9, 12, 13	1, 2, 3, 4, 5, 6, 7, 8	ACC-2E ACC-2E	\$C000, \$C008, \$C010, \$C018, \$C020, \$C028, \$C030, \$C038	ACC-24E2x w/Opt 1x**, ACC-24E2x w/Opt 1x**	\$C040, \$C048, \$C050, \$C058, \$C060, \$C068, \$C070, \$C078	7
<p>If no servo nodes are activated, I/O Node 11 is activated, so communications can be established with the Station.</p> <p>* Specifies backplane channels 3 & 4 (addresses \$C050 and \$C058 on firmware versions V1.114 and older.</p> <p>** Option 1x (1A or 1D) is required to provide the third and fourth channels for ACC-24E2, ACC-24E2A, or ACC-51E. It is not required for ACC-24E2S.</p> <p>*** A setting of F(15) forces the station to use its factory default I-variables on power-up/reset.</p> <p>Note: Certain products using the MACRO Station firmware (not the 3U MACRO Station itself) are shipped with V2.xxx firmware to optimize operation for a single-axis station, as in servo drives with a built-in MACRO interface. In these products, the setting of SW1 determines the single MACRO node that is activated by default. This MACRO node is always mapped into the single machine interface channel on the device.</p>							

MACRO CPU SW2 Setting

The setting of rotary switch SW2 on the MACRO CPU board determines the number (0 to 15) of the master MACRO IC on a PMAC2 or Turbo PMAC2 controller with which the MACRO nodes on this MACRO Station can communicate. This establishes the third mapping step explained in the overview.

A non-Turbo PMAC2 has only a single MACRO IC; its master number is set by I996 on the PMAC2. A Turbo PMAC2 can support up to 4 active MACRO ICs; the master numbers for these ICs are set by I6841, I6891, I6941, and I6991 on the Turbo PMAC2. This set-up is covered in the next section.

Note:

The master number of a MACRO IC on a Turbo PMAC2 is not necessarily the same as the MACRO IC number (0, 1, 2, or 3) itself. However, if there is only a single Turbo PMAC2 on the ring, it is probable that each MACRO IC on the Turbo PMAC2 will be assigned a master number equal to the IC number.

PMAC2 SOFTWARE SETUP FOR MACRO STATION

Setting up the (non-Turbo) PMAC2 board to work with a MACRO Station requires the proper setup of several I-variables for MACRO-specific features. The variables that have special considerations for use with MACRO stations are listed below. The comparable setup for Turbo PMAC2 controllers is covered in the next section.

Note

These are I-variables on the PMAC2 controller itself. The MACRO Station has its own set of setup I-variables, called “MI-variables”, which are detailed in a different section.

Typically, the “P2Setup” program for PCs is used to set up these I-variables. It walks you through each step and confirms the proper operation of each setting.

MACRO Ring Update Frequency Setup

All stations on the MACRO ring must be set to the same ring update frequency. The ring update frequency is fundamentally controlled by the “ring controller” or “synchronizing master”. If the ring controller is a PMAC2, the ring update frequency is the same as the phase clock frequency on the card.

PMAC2 Ultralite: I992 and I997

On a PMAC2 Ultralite controller, the phase clock frequency is determined by I992 and I997. I992 determines the frequency of the “MaxPhase” clock, and I997 determines how the Phase clock frequency is divided down from the MaxPhase clock. I992 sets the MaxPhase frequency according to the formula:

$$\text{MaxPhase Freq. (kHz)} = 117,964.8 / [2 * I992 + 3]$$

To set I992 for a desired MaxPhase frequency, the following formula can be used:

$$I992 = (117,964.8 / [2 * \text{MaxPhase(kHz)}]) - 1 \text{ (rounded down)}$$

I997 sets the Phase clock frequency from the MaxPhase according to the formula:

$$\text{Phase Freq. (kHz)} = \text{MaxPhase Freq. (kHz)} / [I997 + 1]$$

In MACRO applications, typically I997 is set to 0, so the Phase clock frequency equals the MaxPhase clock frequency. In this case, I992 sets the Phase clock frequency, and therefore the MACRO ring update frequency, directly.

PMAC2 (Not Ultralite): I900 and I901

On a PMAC2 controller that is not “Ultralite”, communicating with the MACRO station through an ACC-42P2 MACRO interface board, the phase clock frequency is determined by I900 and I901. I900 determines the frequency of the “MaxPhase” clock, and I901 determines how the Phase clock frequency is divided down from the MaxPhase clock. I900 sets the MaxPhase frequency according to the formula:

$$\text{MaxPhase Freq. (kHz)} = 117,964.8 / [2 * I900 + 3]$$

To set I900 for a desired MaxPhase frequency, the following formula can be used:

$$I900 = (117,964.8 / [2 * \text{MaxPhase(kHz)}]) - 1 \text{ (rounded down)}$$

I901 sets the Phase clock frequency from the MaxPhase according to the formula:

$$\text{Phase Freq. (kHz)} = \text{MaxPhase Freq. (kHz)} / [I901 + 1]$$

In MACRO applications, typically I901 is set to 0, so the Phase clock frequency equals the MaxPhase clock frequency. In this case, I900 sets the Phase clock frequency, and therefore the MACRO ring update frequency, directly.

Notes on Servo Clock

On PMAC2 controllers, the Servo clock frequency is derived from the Phase clock frequency by an integer division, so the setting of the MACRO ring update frequency, which is the same as the Phase clock frequency, determines the possible Servo clock frequencies. The division of the Servo clock frequency from the Phase clock frequency is determined by:

- PMAC2 Ultralite: I998 (Servo Freq. = Phase Freq. / [I998+1])
- PMAC2 (not Ultralite) I902 (Servo Freq. = Phase Freq. / [I902+1])

Once the servo clock frequency has been established, PMAC2 variable I10 must be set accordingly so that trajectories execute at the proper speed. Several MACRO timing variables have units of servo clock cycles.

Even if the PMAC2 controller is not performing commutation or current loop, and therefore not performing any software tasks at the Phase clock frequency, the Phase clock frequency should if possible be set to at least twice the Servo clock frequency. Because the MACRO ring data is transmitted at the Phase clock frequency, the “oversampling” of ring servo data that results eliminates one servo cycle’s delay in transmission of servo loop data, which permits higher servo gains, and better performance.

PMAC2 MACRO Ring Setup I-Variables

1995: MACRO Master & Ring Controller Enable

Any PMAC2 talking to a MACRO Station must be configured as a Master on the ring. Each ring must have one and only one ring controller (synchronizing master).

On a PMAC2, I995 should be set to \$30 to make the card the ring controller. On a PMAC2 that will be a master but not ring controller, I995 should be set to \$90.

1996: MACRO Node Activation Control

I996 on PMAC2 controls which of the 16 MACRO nodes on the card are activated. It also controls the master station number, and the node number of the packet that creates a synchronization signal. The bits of I996 are arranged as follows:

Bits 0-15: Activation of MACRO Nodes 0 to 15, respectively (1 = active, 0 = inactive). These 16 bits individually control the activation of the MACRO nodes in the PMAC2. Each node that is active on the matching MACRO Station, whether for servo, I/O, or auxiliary communications, should have its node activation bit set to 1. Bit 15 should always be set to 1 to enable communications functions over Node 15.

Bits 16-19: Packet Sync Node Slave Number. These 4 bits together form the slave number (0 to 15) of the packet whose receipt by the PMAC2 will set the “Sync Packet Received” status bit. Because Node 15 is active in all configurations, it is best to set these four bits to 15 (\$F). PMAC2 must see this status bit set twice during each I1001 servo cycles; otherwise it will assume ring problems and shut down servo and I/O outputs on the ring. Bit 7 of I995 must be set to 1 on all PMAC2s that are not ring controllers to enable the synchronization of their phase clocks to that of the ring controller based on receipt of the sync packet.

Bits 20-23: Master Number. These 4 bits together form the master number (0 to 15) of the PMAC2 on the MACRO ring. This master number forms half of the address byte with each packet sent by the PMAC2 over the MACRO ring.

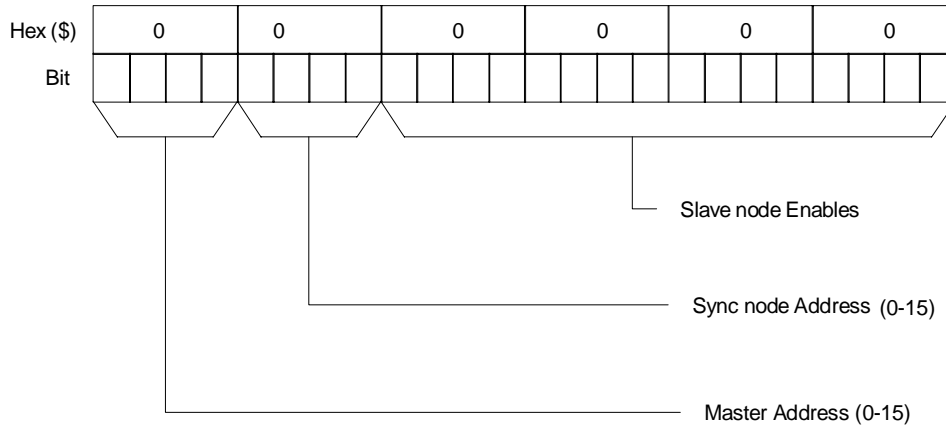

The table shown in an above section and in the Hardware Reference Manual for the 3U MACRO Station’s SW1 switch setting provides a starting point for the PMAC2’s I996 value. Additional bits of I996 may be set to 1 if I/O nodes are enabled or if more than one 3U MACRO station is commanded from a single PMAC2.

I1000: MACRO Node Auxiliary Function Enable

I1000 is a 16-bit I-variable (bits 0 - 15) in which each bit controls the enabling or disabling of the auxiliary flag function for the MACRO node number matching the bit number. A bit value of 1 enables the auxiliary flag function; a bit value of 0 disables it. If the function is enabled, PMAC automatically copies information between the MACRO interface flag register and RAM register \$0F7n (where n is the node number).

Each MACRO node n that is used for servo functions should have the corresponding bit n of I1000 set to 1. Ix25 for the Motor x that uses Node n should address \$0F7n (see below), not the actual MACRO register. If Register 3 of a MACRO node n (normally the flag-transfer register) is used for other purposes, such as direct I/O, the corresponding bit n of I1000 should be set to 0, so this copying function does not overwrite these registers.

The table shown in an above section and in the Hardware Reference Manual for the 3U MACRO Station’s SW1 switch setting provides a starting point for the PMAC2’s I1000 value. Additional bits of I1000 may be set to 1 if more than one 3U MACRO station is commanded from a single PMAC2.

I1002: MACRO Node Protocol Type Control

I1002 is a 16-bit I-variable (bits 0 - 15) in which each bit controls whether PMAC uses the uses MACRO Type 0 protocol or the MACRO Type 1 protocol for the node whose number matches the bit number for the purposes of the auxiliary servo flag transfer. A bit value of 0 sets a Type 0 protocol; a bit value of 1 sets a Type 1 protocol.

All 3U MACRO Station nodes use Type 1, so each MACRO node n used for servo purposes with a MACRO Station must have bit n of I1002 set to 1. Generally I1002 = I1000 on a PMAC communicating with a 3U MACRO Station

The table shown in an above section and in the Hardware Reference Manual for the 3U MACRO Station’s SW1 switch setting provides a starting point for the PMAC2’s I1002 value. Additional bits of I1002 may be set to 1 if more than 1 3U MACRO station is commanded from a single PMAC2.

I1001, I1004, I1005: MACRO Ring Check Period and Limits

If I1001 is set to a value greater than zero, PMAC2 will automatically monitor for MACRO ring breaks or repeated MACRO communications errors. A non-zero value sets the error detection cycle time in PMAC2 servo cycles. PMAC2 checks to see that “sync node” packets (see I995 and I996) are received regularly, and that there have not been regular communications errors.

The limits for these checks can be set by the user with variables I1004 and I005. If less than I1005 sync node packets have been received and detected during this time interval, or if I1004 or more ring communications errors have been detected in this interval, PMAC2 will assume a major ring problem, and all motors will be shut down. PMAC2 will set the global status bit “Ring Error” (bit 4 of X:\$0003) as an indication of this error.

PMAC2 looks for receipt of sync node packets and ring communications errors once per real-time interrupt – every (I8 + 1) servo cycles). The time interval set by I1001 must be large enough that I1005 real-time interrupts in PMAC2 can always execute within the time interval, or false ring errors will be detected. Remember that long motion program calculations can cause “skips” in the real-time interrupt. Typically values of I1001 setting a time interval of about 20 milliseconds are used. I1001 can be set according to the formula:

$$I1001 = \text{Desired cycle time (msec)} * \text{Servo update frequency (kHz)}$$

For example, with the default servo update frequency of 2.26 kHz, to get a ring check cycle interval of 20 msec, I1001 would be set to $20 * 2.26 \cong 45$.

Since the sampling is done every (I8+1) servo cycles, I1004 and I1005 must be set less than $I1001 / (I8+1)$.

I1003: MACRO Master/Slave Auxiliary Timeout

If I1003 is set greater than 0, the MACRO Type 1 Master/Slave Auxiliary Communications protocol using Node 15 is enabled. PMAC2 implements this communications protocol using the **MACROSLAVE (MS)**, **MACROSLVREAD (MSR)**, and **MACROSLVWRITE (MSW)** commands.

If this function is enabled, I1003 sets the “timeout” value in PMAC2 servo cycles. In this case, if PMAC2 does not get a response to a Node 15 auxiliary communications command within I1003 servo cycles, it will stop waiting and register a “MACRO auxiliary communications error”, setting Bit 5 of global status register X:\$0003.

I1003 must be set greater than 0 if any auxiliary communications is desired with a MACRO Station. A value of 32 is suggested. If a value of I1003 greater than 0 has been saved into PMAC2’s non-volatile memory, then at subsequent power-up/resets, bit 15 of I1000 is forced to 0, regardless of the value saved for I1000. This reserves Node 15 for the Type 1 Auxiliary Communications, and it cannot be used for flag transfer.

MACRO Node Addresses

The MACRO ring operates by copying registers at high speed across the ring. Therefore, the each PMAC2 controller on the ring communicates with its slave stations by reading from and writing to registers in its own address space. MACRO hardware automatically handles the data transfers across the ring.

The following table gives the addresses of the MACRO ring registers for PMAC2 controllers. Note that the addresses of the MACRO ring registers in the PMAC2 are the same as the addresses of the matching ring registers in the 3U MACRO Station.

PMAC2 Addresses				
Node #	Reg. 0	Reg. 1	Reg. 2	Reg. 3
0	Y:\$C0A0	Y:\$C0A1	Y:\$C0A2	Y:\$C0A3
1	Y:\$C0A4	Y:\$C0A5	Y:\$C0A6	Y:\$C0A7
2	X:\$C0A0	X:\$C0A1	X:\$C0A2	X:\$C0A3
3	X:\$C0A4	X:\$C0A5	X:\$C0A6	X:\$C0A7
4	Y:\$C0A8	Y:\$C0A9	Y:\$C0AA	Y:\$C0AB
5	Y:\$C0AC	Y:\$C0AD	Y:\$C0AE	Y:\$C0AF
6	X:\$C0A8	X:\$C0A9	X:\$C0AA	X:\$C0AB
7	X:\$C0AC	X:\$C0AD	X:\$C0AE	X:\$C0AF
8	Y:\$C0B0	Y:\$C0B1	Y:\$C0B2	Y:\$C0B3
9	Y:\$C0B4	Y:\$C0B5	Y:\$C0B6	Y:\$C0B7
10	X:\$C0B0	X:\$C0B1	X:\$C0B2	X:\$C0B3
11	X:\$C0B4	X:\$C0B5	X:\$C0B6	X:\$C0B7
12	Y:\$C0B8	Y:\$C0B9	Y:\$C0BA	Y:\$C0BB
13	Y:\$C0BC	Y:\$C0BD	Y:\$C0BE	Y:\$C0BF
14	X:\$C0B8	X:\$C0B9	X:\$C0BA	X:\$C0BB
15	X:\$C0BC	X:\$C0BD	X:\$C0BE	X:\$C0BF

With the MACRO station, only nodes that map into PMAC2 “Y” registers (0, 1, 4, 5, 8, 9, 12, and 13) can be used for servo control. These nodes are unshaded in the above table. The nodes that map into “X” registers (2, 3, 6, 7, 10, 11, and 14) can be used for I/O control. Node 15 is reserved for “Type 1” auxiliary communications. Node 14 is often used for “broadcast” communications. In firmware revisions V1.114 and newer, if MI15 is set to the default value of 0, it comes up ready for ASCII communications and “Who are you querying?”

PMAC2 Conversion Table Setup

PMAC2 processes the raw feedback data they receive through an “encoder conversion table” before the servo loop uses the data for feedback. This table permits various techniques, such as “1/T” extension of encoder data, to refine the feedback values. However, when the MACRO Station is used to provide the feedback, the Station has its own encoder conversion table to do the refinement before the data is sent across the ring. Therefore, all that the PMAC2’s encoder conversion table must do is a simple copying operation out of the MACRO nodes.

Position feedback data for a node from a MACRO station appears in the 24-bit Register 0 for the node. The least significant bit of the register represents 1/32 of a count (i.e. there are 5 bits of fraction).

To process this data for the servo loop (position and/or velocity loop feedback), the PMAC’s conversion table will treat the data as a “parallel” Y word. The conversion will be “unshifted”, because the result is expected to have its LSB represent 1/32 of a count. The conversion format is \$28; the source address is that of the MACRO register itself; and the “bits-enabled mask” is \$FFFFFF to specify the use of all 24 bits.

The conversion table for the PMAC2 to process all 8 servo nodes from a MACRO station is shown below. This forms the default conversion table for the Ultralite versions of the PMAC2. If any changes are required, these can be made interactively through the PMAC Executive program’s Conversion Table setup screen under the *Configure* menu.

PMAC2 Address	PMAC2 Table Instruction Word	Comment
Y:\$0720	\$28C0A0	Unshifted conversion of Node 0 Register 0
Y:\$0721	\$FFFFFF	Use all 24 bits; converted value in X:\$0721
Y:\$0722	\$28C0A4	Unshifted conversion of Node 1 Register 0
Y:\$0723	\$FFFFFF	Use all 24 bits; converted value in X:\$0723
Y:\$0724	\$28C0A8	Unshifted conversion of Node 4 Register 0
Y:\$0725	\$FFFFFF	Use all 24 bits; converted value in X:\$0725
Y:\$0726	\$28C0AC	Unshifted conversion of Node 5 Register 0
Y:\$0727	\$FFFFFF	Use all 24 bits; converted value in X:\$0727
Y:\$0728	\$28C0B0	Unshifted conversion of Node 8 Register 0
Y:\$0729	\$FFFFFF	Use all 24 bits; converted value in X:\$0729
Y:\$072A	\$28C0B4	Unshifted conversion of Node 9 Register 0
Y:\$072B	\$FFFFFF	Use all 24 bits; converted value in X:\$072B
Y:\$072C	\$28C0B8	Unshifted conversion of Node 12 Register 0
Y:\$072D	\$FFFFFF	Use all 24 bits; converted value in X:\$072D
Y:\$072E	\$28C0BC	Unshifted conversion of Node 13 Register 0
Y:\$072F	\$FFFFFF	Use all 24 bits; converted value in X:\$072F

If PMAC2 is doing the commutation for the motor, it is best to use the “previous phase” position register in RAM as the servo feedback register. The commutation algorithm has already read the raw position data from the MACRO ring and copied it into this register, storing it for calculations in its next cycle. Using this register in the conversion table ensures that the servo algorithm uses the same position that the commutation used, even if new data has started coming in from the MACRO ring for the next cycle.

The following table shows the setup of the encoder conversion table when all eight entries use the motor “previous position” registers:

PMAC2 Address	PMAC2 Table Instruction Word	Comment
Y:\$0720	\$28003F	Unshifted conversion of Motor 1 phase position
Y:\$0721	\$FFFFFF	Use all 24 bits; converted value in X:\$0721
Y:\$0722	\$28007B	Unshifted conversion of Motor 2 phase position
Y:\$0723	\$FFFFFF	Use all 24 bits; converted value in X:\$0723
Y:\$0724	\$2800B7	Unshifted conversion of Motor 3 phase position
Y:\$0725	\$FFFFFF	Use all 24 bits; converted value in X:\$0725
Y:\$0726	\$2800F3	Unshifted conversion of Motor 4 phase position
Y:\$0727	\$FFFFFF	Use all 24 bits; converted value in X:\$0727
Y:\$0728	\$28012F	Unshifted conversion of Motor 5 phase position
Y:\$0729	\$FFFFFF	Use all 24 bits; converted value in X:\$0729
Y:\$072A	\$28016B	Unshifted conversion of Motor 6 phase position
Y:\$072B	\$FFFFFF	Use all 24 bits; converted value in X:\$072B
Y:\$072C	\$2801A7	Unshifted conversion of Motor 7 phase position
Y:\$072D	\$FFFFFF	Use all 24 bits; converted value in X:\$072D
Y:\$072E	\$2801E3	Unshifted conversion of Motor 8 phase position
Y:\$072F	\$FFFFFF	Use all 24 bits; converted value in X:\$072F

Sometimes the conversion table will process data sent back to PMAC2 through “I/O” nodes, which are mapped into PMAC2 as X-registers. This is often done in cases of dual feedback or “loop-around-loop” configurations. Because these I/O nodes use X-registers instead of Y-registers, they use the \$6 conversion method.

The following table shows entries for processing the data in the 24-bit register 0 of the first six I/O nodes. The entries are shown at addresses so they would be appended to the end of one of the above tables.

PMAC2 Address	PMAC2 Table Instruction Word	Comment
Y:\$0730	\$68C0A0	Unshifted conversion of Node 2 Register 0
Y:\$0731	\$FFFFFF	Use all 24 bits; converted value in X:\$0731
Y:\$0732	\$68C0A4	Unshifted conversion of Node 3 Register 0
Y:\$0733	\$FFFFFF	Use all 24 bits; converted value in X:\$0733
Y:\$0734	\$68C0A8	Unshifted conversion of Node 6 Register 0
Y:\$0735	\$FFFFFF	Use all 24 bits; converted value in X:\$0735
Y:\$0736	\$68C0AC	Unshifted conversion of Node 7 Register 0
Y:\$0737	\$FFFFFF	Use all 24 bits; converted value in X:\$0737
Y:\$0738	\$68C0B0	Unshifted conversion of Node 10 Register 0
Y:\$0739	\$FFFFFF	Use all 24 bits; converted value in X:\$0739
Y:\$073A	\$68C0B4	Unshifted conversion of Node 11 Register 0
Y:\$073B	\$FFFFFF	Use all 24 bits; converted value in X:\$073B

PMAC2 Motor I-Variables

Ix02: Command Output Address

Ix02 specifies the address of the (first) register where PMAC2 writes the command output value(s) for Motor x. In standard operation of a servo axis, the motor must write the command value or the first of several command values to Register 0 of the servo node. With the MACRO station, the proper values for Ix02 for each node, regardless of the servo output mode – velocity, torque, phase current (sine-wave output, including “direct microstepping”), or phase voltage (direct PWM) – are:

Node #	PMAC2 Ix02 Value	Node #	PMAC2 Ix02 Value
Node 0	\$C0A0	Node 8	\$C0B0
Node 1	\$C0A4	Node 9	\$C0B4
Node 4	\$C0A8	Node 12	\$C0B8
Node 5	\$C0AC	Node 13	\$C0BC

If Motor x is used to produce a pulse-and-direction output on the MACRO Station to control a traditional stepper drive or a “stepper-replacement” servo drive, the command output should be written to Register 2 of the servo node. In this mode, the proper values of Ix02 are:

Node #	PMAC2 Ix02 Value	Node #	PMAC2 Ix02 Value
Node 0	\$C0A2	Node 8	\$C0B2
Node 1	\$C0A6	Node 9	\$C0B6
Node 4	\$C0AA	Node 12	\$C0BA
Node 5	\$C0AE	Node 13	\$C0BE

Ix03, Ix04: Feedback Address

Ix03 and Ix04 specify the addresses of the registers that PMAC2 reads to get its position-loop and velocity-loop feedback values. Usually, this is a “result” register in the encoder conversion table. Unless the motor uses dual feedback, the values of Ix03 and Ix04 are the same, which means the same sensor is used for both position-loop and velocity-loop feedback.

Note:

The automatic servo node functions on a MACRO Station do not support dual feedback in a single node. For dual feedback, either a second servo node must be used, or one of the feedback values (usually the velocity-loop feedback position) must be sent back to the PMAC2 as an “I/O” value.

With either of the conversion tables suggested above, the settings of Ix03 and Ix04 should be:

Node #	Ix03/4 Value	Node #	Ix03/4 Value
Node 0	\$0721	Node 8	\$0729
Node 1	\$0723	Node 9	\$072B
Node 4	\$0725	Node 12	\$072D
Node 5	\$0727	Node 13	\$072F

These are the default values of Ix03 and Ix04 for Motors 1 through 8, respectively, on Ultralite PMAC2s.

Ix10: Power-On Feedback Address

Ix10 permits an automatic read of an absolute position sensor at power-on/reset, and/or on a subsequent \$* or \$\$* command. If Ix10 is set to 0, the power-on/reset position for the motor will be considered to be 0, regardless of the type of sensor used. There are specific settings of PMAC2’s Ix10 for each type of MACRO interface. The 3U MACRO Station has a corresponding variable I11x for each node that must be set.

3U MACRO Station Feedback Type	PMAC2 Ix10 (Unsigned)	Station MI11x (Unsigned)	PMAC2 Ix10 (Signed)	Station MI11x (Signed)
ACC-8D Opt 7 Resolver/Digital Converter	\$73000n	\$00xxxx - \$07xxxx	\$F3000n	\$80xxxx - \$87xxxx
ACC-8D Opt 9 Yaskawa Absolute Encoder Converter	\$72000n	\$71xxxx - \$72xxxx	\$F2000n	\$F1xxxx - \$F2xxxx
ACC-49 Sanyo 26-bit Absolute Encoder Converter	\$74000n	\$32xxxx	\$F4000n	\$B2xxxx
ACC-28B/E Analog/Digital Converter	\$74000n	\$31xxxx	--	--
ACC-1E/6E/36E/59E A/D Converter (low 12 bits)	\$74000n	\$0Cxxxx	\$F4000n	\$8Cxxxx
ACC-1E/6E/36E/59E A/D Converter (high 12 bits)	\$74000n	\$33xxxx	\$F4000n	\$B3xxxx
MACRO Station MLDT Input	\$74000n	\$17xxxx	--	--
MACRO Station Parallel Input (from 24-bit word)	\$74000n	\$08xxxx - \$2Axxxx	\$F4000n	\$88xxxx - \$AAxxxx
ACC-3E/14E Parallel Input from 2 consecutive lower bytes	\$74000n	\$2Bxxxx	\$F4000n	\$ABxxxx
ACC-3E Parallel Input from 2 consecutive middle bytes	\$74000n	\$2Cxxxx	\$F4000n	\$ACxxxx
ACC-3E Parallel Input from 2 consecutive upper bytes	\$74000n	\$2Dxxxx	\$F4000n	\$ADxxxx

ACC-3E/14E Parallel Input from 2 consecutive lower bytes	\$74000n	\$2Exxxx	\$F4000n	\$AExxxx
ACC-3E Parallel Input from 2 consecutive middle bytes	\$74000n	\$2Fxxxx	\$F4000n	\$AFxxxx
ACC-3E Parallel Input from 2 consecutive upper bytes	\$74000n	\$30xxxx	\$F4000n	\$B0xxxx
'n' is the MACRO node number used for Motor x: 0, 1, 4, 5, 8, 9, C(12), or D(13).				

When PMAC2 has Ix10 set to get absolute position over MACRO, it executes a station auxiliary read command **MS{node}, I920** to request the absolute position from the 3U MACRO Station. The Station then references its own I11x value to determine the type, format, and address of the data to be read. The data is returned to PMAC2 with up to 42 bits of data, sign extended to 46 bits. Bit 48 is a Ready/Busy handshake bit and Bit 47 is a pass/fail status bit. If Bit 47 is set, the upper 24 bits of the 48 bits returned are a fail word and are stored in X:\$0798 of the PMAC2.

Ix25: Flag Address

If the auxiliary functions for Node *n* have been enabled by setting Bit *n* of I1000 to 1, the flag information in Register 3 for the node is automatically copied to and from PMAC RAM register \$0F7n. The low 16 bits of Ix25 should specify the address of the RAM copy, not the actual MACRO interface register.

Bit 18 of Ix25 must be set to 1 to specify that the flags are sent and received across MACRO. Bit 23 of Ix25 must match the setting of the matching bit of MACRO Station variable MI18 as to the polarity of the amplifier fault input. If the bit of MI18 is set to 0 to specify a low-true fault (logical 0 is fault, regardless of input voltage), bit 23 of Ix25 must also be set to 0. However, if the bit of MI18 is set to 1 to specify high-true fault signals (logical 1 is fault), bit 23 of Ix25 must also be set to 1.

With the flags used in the default mode, the value of Ix25 to use flags from Node *n* is \$040F7n (\$840F7n for high-true faults). These values for the 8 possible servo nodes from MACRO Stations are:

Node #	Ix25 Value	Node #	Ix25 Value
Node 0	\$040F70	Node 8	\$040F78
Node 1	\$040F71	Node 9	\$040F79
Node 4	\$040F74	Node 12	\$040F7C
Node 5	\$040F75	Node 13	\$040F7D

These are the default values of Ix25 for Motors 1 through 8, respectively, on Ultralite PMAC2s. Other bits of Ix25 may also be set to disable use of the fault, overtravel limit, and amplifier-enable flags.

When Bit 18 of Ix25 is set to 1, and bit *n* of I1000 is set to 1, then the Motor *x* flag information is automatically copied between the holding registers at \$0F7n and the MACRO interface registers for node *n* on the PMAC. The command flags, such as amplifier enable, are held in the Y-register of \$0F7n. The feedback flags, such as overtravel limits and amplifier fault, are held in the X-registers of \$0F7n. Monitoring of flag values should use these holding registers in RAM, not the actual MACRO node registers.

The following tables show the locations of the individual flags in these registers.

Motor Command Flags: Y:\$0F7n for Node n

Bit #	Function	Notes
0	Position Capture Prepare Flag	Must be set to 1 to prepare for hardware capture over ring; to 0 when done
1-7	(Not Used)	
8-10	(reserved for future use)	
11	Position Capture Enable Flag	Must be set to 1 to prepare for hardware capture over ring; to 0 when done
12	Node Position Reset Flag	
13	(reserved for future use)	
14	Amplifier Enabled	Command to Station
15-23	(reserved for future use)	

Motor Status Flags: X:\$0F7n for Node n

Bit #	Function	Notes
0-7	(Not Used)	
8-10	(reserved for future use)	
11	Position Captured Flag	Latched from selected flag
12	Power-On Reset or Node Reset Occurred	
13	Ring Break Detected Elsewhere	
14	Amplifier Enabled	Status from Station
15	Amplifier/Node Shutdown Fault	1 is treated as shutdown if Ix25 bit 23 = 1; 0 if Ix25 bit 23 = 0
16	Home Flag (HOME) Input Value	
17	Positive Limit Flag (PLIM) Value	
18	Negative Limit Flag (MLIM) Value	
19	User Flag (USER) Input Value	
20	Flag W Input Value	
21	Flag V Input Value	
22	Flag U Input Value	
23	Flag T Input Value	

Ix70, Ix71: Commutation Cycle Size

If the PMAC2 is performing commutation for Motor x, providing either 2 phase current commands (“sine-wave output”) or 3 PWM phase voltage commands (“direct PWM output”), the size of the commutation cycle in encoder counts is equal to Ix71/Ix70. Because the MACRO station provides position feedback in units of 1/32 count for both servo and commutation, the value of Ix70 and Ix71 must be set to provide a ratio 32 times the number of true counts in the commutation cycle.

For example, if the commutation cycle has 1000 encoder counts, Ix70 could be set to 1 and Ix71 could be set to 32,000.

Ix75: Absolute Phase Position Offset

If Ix81 (see below) is set to a value greater than 0, then PMAC2 will read an absolute sensor for power-on phase position, and it will use Ix75 to determine the difference between the absolute sensor’s zero position and the phase commutation cycle’s zero position.

Normally, this position difference in Ix75 is expressed in counts multiplied by Ix70. However, when the absolute position is read from a Yaskawa absolute encoder through an ACC-8D Opt 9 and a 3U MACRO Station, then Ix75 is expressed in units of 1/32 of a count multiplied by Ix70.

Ix81: Power-On Phase Position Address

Ix81 permits an automatic read of an absolute position sensor for phase referencing at power-on/reset (if Ix80 = 1 or 3), or on the \$ command. If Ix81 is set to 0, the power-on/reset position for the motor will be considered to be 0, regardless of the type of sensor used. There are specific settings of PMAC2's Ix81 for each type of MACRO interface. The 3U MACRO Station has a corresponding variable MI1x for each node that must be set.

3U MACRO Station Feedback Type	Ix81 Value	Station MI1x Bits 16-23
ACC-8D Opt 7 Resolver/Digital Converter	\$73000n	\$00-\$07 (\$80-\$87)
ACC-8D Opt 9 Yaskawa Absolute Encoder Converter	\$bb{node address}	See Note 1
ACC-49 Sanyo Absolute Encoder Converter	\$74000n	\$0D
ACC-28B/E Analog/Digital Converter	\$74000n	\$31
MACRO Station Hall Sensor Flag Input	\$vv0F7n	See Note 2
ACC-1E/6E/36E/59E A/D Converter (low 12 bits)	\$74000n	\$0C (\$8C)
ACC-1E/6E/36E/59E A/D Converter (high 12 bits)	\$74000n	\$33 (\$B3)
MACRO Station Parallel Input	\$74000n	\$08-\$30 (\$88-\$B0)
MACRO Station MLDT Input	\$74000n	\$08-\$30 (\$88-\$B0)
ACC-3E/14E Parallel Input from 2 consecutive lower bytes	\$74000n	\$2B (\$AB)
ACC-3E Parallel Input from 2 consecutive middle bytes	\$74000n	\$2C (\$AC)
ACC-3E Parallel Input from 2 consecutive upper bytes	\$74000n	\$2D (\$AD)
ACC-3E/14E Parallel Input from 2 consecutive lower bytes	\$74000n	\$2E (\$AE)
ACC-3E Parallel Input from 2 consecutive middle bytes	\$74000n	\$2F (\$AF)
ACC-3E Parallel Input from 2 consecutive upper bytes	\$74000n	\$30 (\$B0)
'n' is the MACRO node number used for Motor xx: 0, 1, 4, 5, 8, 9, C(12), or D(13). 'bb' is the number of bits in a revolution of the encoder (e.g. 13 bits for 8192 counts) plus 5 (to account for the 5 fractional bits), expressed in hexadecimal format (e.g. for 8192 counts/rev, 13 + 5 = 18 = \$12) {node address} is the PMAC2 address of Register 0 of the MACRO servo node used (\$C0A0 for Node 0, \$C0A4 for Node 1, etc.) 'vv' is a value from \$80 to \$FF representing the Hall sensor offset and direction.		

For purposes of absolute phase position, Turbo PMAC2 simply reads the encoder counter value in its own MACRO node, communicated automatically by the servo node functions. The MI1x setting is not used to obtain the phase position, but it will probably be set to \$71xxxx or \$F1xxxx for absolute servo position.

For purposes of absolute phase position, Turbo PMAC2 simply reads the hall sensor values in its own MACRO node, communicated automatically by the auxiliary servo node functions. The MI1x setting is not used here, but may be set to a non-zero value if an absolute servo position sensor is also used.

For the most common version of the Yaskawa encoder with 8192 counts per revolution the settings of Ix81 for each node are:

Node #	PMAC2	Node #	PMAC2
Node 0	\$12C0A0	Node 8	\$12C0B0
Node 1	\$12C0A4	Node 9	\$12C0B4
Node 4	\$12C0A8	Node 12	\$12C0B8
Node 5	\$12C0AC	Node 13	\$12C0BC

When PMAC2 has Ix81 set to get absolute position over MACRO, it executes a station auxiliary read command **MS{node} ,MI920** to request the absolute position from the MACRO Station. The station then references its own M11Ix value to determine the type, format, and address of the data to be read. The data is returned to PMAC2 with up to 42 bits of data, sign extended to 46 bits. Bit 48 is a Ready/Busy handshake bit and Bit 47 is a pass/fail status bit. If Bit 47 is set, the upper 24 bits of the 48 bits returned are a “fail word” and are stored in X:\$0798 of the PMAC2.

Ix82: Current Loop Feedback Address

If Motor x of the PMAC2 is being operated in direct PWM mode, Ix82 must specify the address of the Phase B current feedback register. If it is not being operated in direct PWM mode, Ix82 must be set to 0.

The proper settings of Ix82 for each node number for direct-PWM use with a MACRO station are:

Node #	Ix82 Value	Node #	Ix82 Value
Node 0	\$C0A2	Node 8	\$C0B2
Node 1	\$C0A6	Node 9	\$C0B6
Node 4	\$C0AA	Node 12	\$C0BA
Node 5	\$C0AE	Node 13	\$C0BE

Ix83: Commutation Feedback Address

If the PMAC2 is performing commutation for Motor x, providing either 2 phase current commands (“sine-wave output”) or 3 PWM phase voltage commands (“direct PWM”), bits 0 – 15 of Ix83 must specify the address of the ongoing commutation position feedback.

The proper settings of Ix83 for using each servo node from a MACRO Station for commutation position feedback are:

Node #	PMAC2	Node #	PMAC2
Node 0	\$8C0A0	Node 8	\$8C0B0
Node 1	\$8C0A4	Node 9	\$8C0B4
Node 4	\$8C0A8	Node 12	\$8C0B8
Node 5	\$8C0AC	Node 13	\$8C0BC
The ‘8’ in the first digit specifies that the PMAC or PMAC2 reads a ‘Y’ register instead of the typical ‘X’ register for the commutation feedback.			

TURBO PMAC2 SOFTWARE SETUP FOR MACRO STATION

Setting up the Turbo PMAC2 board to work with a MACRO Station requires the proper setup of several I-variables for MACRO-specific features. The variables that have special considerations for use with MACRO stations are listed below. The comparable setup for “non-Turbo” PMAC2 controllers is covered in the previous section.

Note:

These are I-variables on the Turbo PMAC2 controller itself. The MACRO Station has its own set of setup I-variables, called “MI-variables”, which are detailed in a different section.

Typically, the “Turbo Setup” program for PCs is used to set up these I-variables. It walks you through each step and confirms the proper operation of each setting.

MACRO IC Address Specification

Turbo PMAC2 firmware provides automatic support for up to four MACRO ICs at one time, known as MACRO ICs 0, 1, 2, and 3. Prior to firmware revision V1.936, each of these four ICs had a fixed base address: \$078400 for MACRO IC 0, \$079400 for MACRO IC 1, \$07A400 for MACRO IC 2, and \$07B400 for MACRO IC 3.

Turbo PMAC2 boards without a built-in MACRO interface support only MACRO IC 0 at the fixed address of \$078400. Turbo PMAC2 Ultralite boards can also support MACRO ICs 1, 2, and 3 if the appropriate options are ordered:

- Option 1U1: MACRO IC 1 at \$079400
- Option 1U2: MACRO IC 2 at \$07A400
- Option 1U3: MACRO IC 3 at \$07B400

The introduction of the UMAC Turbo (3U Turbo PMAC2) allowed more possibilities for addressing MACRO ICs, which required a more flexible firmware structure. Therefore, starting in Turbo PMAC2 firmware revision V1.936, variables I20, I21, I22, and I23 are used to specify the base addresses of MACRO ICs 0, 1, 2, and 3, respectively. Almost always these will be at the default values of \$078400, \$079400, \$07A400, and \$07B400, but other values are possible in a UMAC Turbo system with multiple ACC-5E MACRO interface boards.

MACRO Ring Update Frequency Setup

The discussions of MACRO node addresses below all assume that I20, I21, I22, and I23 are set to their factory default values.

All stations on the MACRO ring must be set to the same ring update frequency. The ring update frequency is fundamentally controlled by the “ring controller” or “synchronizing master”. If the ring controller is a Turbo PMAC2, the ring update frequency is the same as the hardware phase clock frequency on the card.

I7: Phase Cycle Extension

On the Turbo PMAC2 board, it is possible to skip hardware phase clock cycles between executions of the phase update software. A Turbo PMAC2 board will execute the phase update software – commutation and/or current-loop closure – every (I7+1) hardware phase clock cycles. The default value for I7 is 0, so normally Turbo PMAC2 executes the phase update software every hardware phase clock cycle.

If the Turbo PMAC2 board is closing the current loop for direct PWM control over the MACRO ring, it is desirable to have two hardware ring update cycles (which occur at the hardware phase clock frequency) per software phase update. This eliminates one software cycle of delay in the current loop, which permits slightly higher gains and performance. To do this, I7 would be set to 1, so the phase update software would execute every second hardware phase clock cycle, and ring update cycle.

Normally it is desirable to close the current loop at an update rate of about 9 kHz (the default rate). If two ring updates are desired per current loop update, the ring update frequency would need to be set to 18 kHz. This is possible if there are no more than 40 total active nodes on the ring. To implement this, I6800 or I7000 (see below) would be set to one-half of the default value.

Note:

When making this change, the Turbo PMAC's I6800/I7000 variable should be changed first, then the MACRO Station's MI992. Changing the MACRO Station's MI992 alone, followed by an **MSSAVE** command and an **M\$\$\$\$**, could cause the Station's watchdog timer to trip.

I19: Clock Source I-Variable Number

I19 determines which IC (Servo IC or MACRO IC) in a Turbo PMAC2 system is the source of the phase and servo clocks for the system. It contains the number of the "IC Servo/Phase Clock Direction" I-variable whose value is set to 0 by default to indicate that it should use its own clock signals and output them to the rest of the system. (The equivalent variable for other Servo and MACRO ICs should be set to 3 by default to indicate that these ICs should receive their clock signals as inputs. Note that "MACROGATE" MACRO ICs that are typically used for MACRO ICs 1, 2, and 3 have no servo clock – they cannot be used as the system clock source, and even if their clock-direction I-variable is set to 3, it will report back as 1 to indicate phase-clock input.)

In almost all Turbo PMAC2 systems interfacing to a MACRO Station, MACRO IC 0 should be the source of the system servo and phase clock signals. The clock-direction I-variable for MACRO IC 0 is I6807, so I19 on these systems should be set to 6807.

Turbo PMAC2 Ultralite: I6800 and I6801

On a Turbo PMAC2 Ultralite controller, the phase clock frequency is determined by I6800 and I6801. I6800 determines the frequency of the "MaxPhase" clock, and I6801 determines how the Phase clock frequency is divided down from the MaxPhase clock. I6800 sets the MaxPhase frequency according to the formula:

$$\text{MaxPhase Freq. (kHz)} = 117,964.8 / [2 * I6800 + 3]$$

To set I6800 for a desired MaxPhase frequency, the following formula can be used:

$$I6800 = (117,964.8 / [2 * \text{MaxPhase(kHz)}]) - 1 \text{ (rounded down)}$$

I6801 sets the Phase clock frequency from the MaxPhase according to the formula:

$$\text{Phase Freq. (kHz)} = \text{MaxPhase Freq. (kHz)} / [I6801 + 1]$$

In MACRO applications, typically I6801 is set to 0, so the Phase clock frequency equals the MaxPhase clock frequency. In this case, I6800 sets the Phase clock frequency, and therefore the MACRO ring-update frequency, directly.

Turbo PMAC2 (Not Ultralite): I7000 and I7001

On a Turbo PMAC2 controller that is not “Ultralite” or “UMAC”, communicating with the MACRO station through an ACC-42P2 MACRO interface board, the phase clock frequency is determined by I7000 and I7001. I7000 determines the frequency of the “MaxPhase” clock, and I7001 determines how the Phase clock frequency is divided down from the MaxPhase clock. I7000 sets the MaxPhase frequency according to the formula:

$$\text{MaxPhase Freq. (kHz)} = 117,964.8 / [2 * I7000 + 3]$$

To set I7000 for a desired MaxPhase frequency, the following formula can be used:

$$I7000 = (117,964.8 / [2 * \text{MaxPhase(kHz)}]) - 1 \text{ (rounded down)}$$

I7001 sets the Phase clock frequency from the MaxPhase according to the formula:

$$\text{Phase Freq. (kHz)} = \text{MaxPhase Freq. (kHz)} / [I7001 + 1]$$

In MACRO applications, typically I7001 is set to 0, so the Phase clock frequency equals the MaxPhase clock frequency. In this case, I7000 sets the Phase clock frequency, and therefore the MACRO ring-update frequency, directly.

UMAC Turbo

In a UMAC Turbo (3U Turbo PMAC2) system, the Phase clock can come from many possible sources, set by a variety of different variables. However, if a UMAC Turbo system is controlling a MACRO Station through the ring with a ACC-5E MACRO interface board, the MACRO IC 0 on the ACC-5E should be the source of the phase clock for the system. To accomplish this, make sure that I19 is set to 6807 to specify MACRO IC 0 as the clock source for the system, with I6800 and I6801 set to specify the phase clock frequency, as in Ultralite PMAC2 boards, explained above. Normally, the Turbo firmware will automatically select MACRO IC 0 on a UMAC, if present, as the clock source on a \$\$\$*** re-initialization command.

Notes on Servo Clock

On Turbo PMAC2 controllers, the Servo clock frequency is derived from the Phase clock frequency by an integer division, so the setting of the MACRO ring update frequency, which is the same as the Phase clock frequency, determines the possible Servo clock frequencies. The division of the Servo clock frequency from the Phase clock frequency is determined by:

- Turbo PMAC2 Ultralite: I6802 (Servo Freq. = Phase Freq. / [I6802+1])
- Turbo PMAC2 (not Ultralite) I7002 (Servo Freq. = Phase Freq. / [I7002+1])

Once the servo clock frequency has been established, the Turbo PMAC2 variable I10 must be set accordingly so trajectories execute at the proper speed. Several MACRO timing variables have units of servo clock cycles.

Even if the Turbo PMAC2 controller is not performing commutation or current-loop closure, and therefore not performing any software tasks at the Phase clock frequency, the Phase clock frequency should if possible be set to at least twice the Servo clock frequency. Because the MACRO ring data is transmitted at the Phase clock frequency, the “oversampling” of ring servo data that results eliminates one servo cycle’s delay in transmission of servo loop data, which permits higher servo gains, and better performance.

Turbo PMAC2 MACRO Ring Setup I-Variables

I6840: MACRO IC 0 Master Configuration

Any MACRO IC on a Turbo PMAC2 talking to a MACRO Station must be configured as a “master” on the ring. For purposes of the MACRO protocol, each MACRO IC is a separate logical “master” with its own master number, even though there may be multiple MACRO ICs on a single physical Turbo PMAC2.

Each ring must have one and only one ring controller (synchronizing master). This should be the MACRO IC 0 one and only one of the Turbo PMAC2 boards on the ring.

On a Turbo PMAC2, I6840 should be set to \$30 to make the card’s MACRO IC 0 the ring controller. This sets bits 4 and 5 of the variable to 1. Setting bit 4 to 1 makes the IC a “master” on the ring; setting bit 5 to 1 makes the IC the “ring controller”, starting each ring cycle by itself.

On a Turbo PMAC2 whose MACRO IC 0 will be a master but not ring controller, I6840 should be set to \$90. This sets bits 4 and 7 of the variable to 1. Setting bit 4 to 1 makes the IC a “master” on the ring; setting bit 7 to 1 will cause this IC to be synchronized to the ring controller IC every time it receives a ring packet specified by I6841.

I6890/I6940/I6990: MACRO IC 1/2/3 Master Configuration

A Turbo PMAC2 Ultralite may have additional MACRO ICs if Options 1U1, 1U2, and/or 1U3 are ordered. A UMAC Turbo system may have additional MACRO ICs if Option 1 on an ACC-5E is ordered, or if multiple ACC-5E boards are ordered. These additional ICs should be set to be masters but not ring controllers by setting I6890, I6940, and I6990, respectively to \$10. This sets bit 4 of the variable to 1, making the IC a “master” on the ring. These ICs should never be synchronizing masters, and since they do not control the clock signals on their own board, their internal clocks do not need to be synchronized to the ring (only MACRO IC 0 needs to do this).

I6841/I6891/I6941/I6991: MACRO IC 0/1/2/3 Node Activation Control

I6841, I6891, I6941, and I6991 on Turbo PMAC2 control which of the 16 MACRO nodes for MACRO ICs 0, 1, 2, and 3, respectively, on the card are activated. They also control the master station number for their respective ICs, and the node number of the packet that creates a synchronization signal. The bits of these I-variables are arranged as follows:

Bits 0-15: Activation of MACRO Nodes 0 to 15, respectively (1 = active, 0 = inactive). These 16 bits (usually read as four hex digits) individually control the activation of the MACRO nodes in the MACRO IC on a Turbo PMAC2. Each node that is active on the matching MACRO Station, whether for servo, I/O, or auxiliary communications, should have its node activation bit set to 1. When working with a Delta Tau MACRO Station, Node 15 of each MACRO IC on a Turbo PMAC2 must be activated to permit auxiliary communications, so bit 15 of this variable should always be set to 1 if the IC is used to communicate with a MACRO Station.

Bits 16-19: Packet Sync Node Slave Number. These 4 bits together (usually read as one hex digit) form the slave number (0 to 15) of the packet whose receipt by the PMAC2 will set the “Sync Packet Received” status bit in the MACRO IC. This digit is almost always set to \$F (15), because Node 15 is always activated.

Turbo PMAC2 must see this bit set regularly; otherwise it will assume ring problems and shut down servo and I/O outputs on the ring. Bit 7 of I6840 must be set to 1 on the MACRO IC 0 of all Turbo PMAC2s that are not ring controllers to enable the synchronization of their phase clocks to that of the ring controller based on receipt of the sync packet.

Bits 20-23: Master Number. These 4 bits together form the master number (0 to 15) of the MACRO IC on the MACRO ring. Each MACRO IC acting as a master on the ring, whether on

the same card or different cards, must have its own master number, and acts as a separate master station for the purposes of the ring protocol. This master number forms half of the address byte with each packet sent by the PMAC2 over the MACRO ring.

The master number can be the same number as the MACRO IC number (e.g. MACRO IC 0 has master number 0, MACRO IC 1 has master number 1, and so on), and if there is only one Turbo PMAC2 in the ring, this will probably be the case. However, this is not required. The MACRO IC that is the ring controller must have master number 0 if Type 1 master-to-master auxiliary communications are to be used.

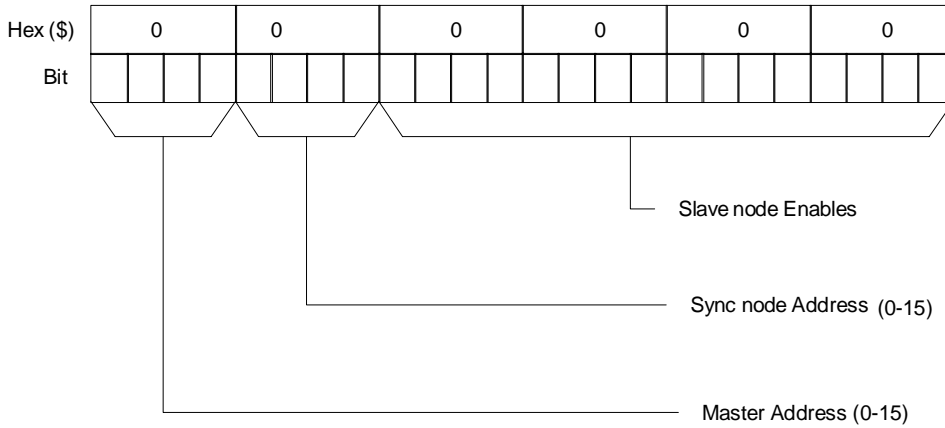

The table shown in an above section and in the Hardware Reference Manual for the 3U MACRO Station’s SW1 switch setting provides a starting point for the Turbo PMAC2’s I6841/I6891/I6941/I6991 value. Additional bits of these I-variables may be set to 1 if I/O nodes are enabled or if more than one 3U MACRO station is commanded from a single MACRO IC.

I70/I72/I74/I76: MACRO IC 0/1/2/3 Node Auxiliary Function Enable

I70, I72, I74, and I76 are 16-bit I-variables (bits 0 - 15) in which each bit controls the enabling or disabling of the auxiliary flag function for the MACRO node number matching the bit number for MACRO ICs 0, 1, 2, and 3, respectively. A bit value of 1 enables the auxiliary flag function; a bit value of 0 disables it. If the function is enabled, PMAC copies information automatically between the MACRO interface flag register and RAM register \$00344n, \$00345n, \$00346n, and \$00347n (where n is the IC’s node number 0 – 15) for MACRO ICs 0, 1, 2, and 3, respectively.

Note:

Turbo PMAC MACRO node numbers (as opposed to individual MACRO IC node numbers) go from 0 to 63, with board nodes 0 – 15 on MACRO IC 0, board nodes 16 – 31 on MACRO IC 1, board nodes 32 – 47 on MACRO IC 2, and board nodes 48 – 63 on MACRO IC 3.

Each MACRO node n that is used for servo functions should have the corresponding bit n of I70, I72, I74, or I76 set to 1. Ixx25 for the Motor x that uses Node n should then address \$00344n, \$00345n, \$00346n, or \$00347n, not the address of the MACRO register itself (see below). If Register 3 of a MACRO node n is used for other purposes, such as direct I/O, the corresponding bit n of I70, I72, I74, or I76 should be set to 0, so this copying function does not overwrite these registers.

Typically, non-servo I/O functions with a MACRO Station do not involve auxiliary flag functions, so this flag copy function should remain disabled for any node used to transmit I/O between the Turbo PMAC2 and the MACRO Station. If any auxiliary communications is done

between the Turbo PMAC2 and the MACRO Station on Nodes 14 and/or 15, bits 14 and 15 of these variables must be set to 0.

Examples

I70=\$3 ; Enabled for MACRO IC 0 Nodes 0 and 1
I72=\$30 ; Enabled for MACRO IC 1 Nodes 4 and 5
I74=\$3300 ; Enabled for MACRO IC 2 Nodes 8, 9, 12, and 13
I76=\$3333 ; Enabled for MACRO IC 3 Nodes 0, 1, 4, 5, 8, 9, 12, and 13

I71/I73/I75/I77: MACRO IC 0/1/2/3 Node Protocol Type Control

I71, I73, I75, and I77 are 16-bit I-variables (bits 0 - 15) in which each bit controls whether PMAC uses the uses MACRO Type 0 protocol or the MACRO Type 1 protocol for the node whose number matches the bit number for the purposes of the auxiliary servo flag transfer for MACRO ICs 0, 1, 2, and 3, respectively. A bit value of 0 sets a Type 0 protocol; a bit value of 1 sets a Type 1 protocol.

All 3U MACRO Station nodes use the Type 1 protocol, so each MACRO node *n* used for servo purposes with a MACRO Station must have bit *n* of I1002 set to 1. Generally I71 = I70, I73 = I72, I75 = I74, and I77 = I76 on a Turbo PMAC2 communicating with a MACRO Station.

Remember that if servo nodes for more than one MACRO Station are commanded from a single MACRO IC, the protocol must be selected for all of the active servo nodes on each station.

I78: MACRO Master/Slave Auxiliary Communications Timeout

If I78 is set greater than 0, the MACRO Type 1 Master/Slave Auxiliary Communications protocol using Node 15 is enabled. Turbo PMAC implements this communications protocol using the **MACROSLAVE (MS)**, **MACROSLVREAD (MSR)**, and **MACROSLVWRITE (MSW)** commands.

If this function is enabled, I78 sets the “timeout” value in PMAC servo cycles. In this case, if PMAC does not get a response to a Node 15 auxiliary communications command within I78 servo cycles, it will stop waiting and register a “MACRO auxiliary communications error”, setting Bit 5 of global status register X:\$000006.

I78 must be set greater than 0 if any auxiliary communications is desired with a MACRO Station. This reserves Node 15 for the Type 1 Auxiliary Communications. A value of 32 is suggested. If I78 is set greater than 0, bit 15 of I70, I72, I74, and I76 must be set to 0, so Node 15 is not also used for flag transfers.

I79: MACRO Master/Master Auxiliary Communications Timeout

If I79 is set greater than 0, the MACRO Type 1 Master/Master Auxiliary Communications protocol using Node 14 is enabled. Turbo PMAC implements this communications protocol using the **MACROMASTER (MM)**, **MACROMSTREAD (MMR)**, and **MACROMSTWRITE (MMW)** commands. Only the Turbo PMAC that is the “ring controller” can execute these commands; other Turbo PMACs that are masters on the ring can respond to these commands from the ring controller.

If this function is enabled, I79 sets the “timeout” value in PMAC servo cycles. In this case, if the Turbo PMAC does not get a response to a Node 14 master/master auxiliary communications command within I79 servo cycles, it will stop waiting and register a “MACRO auxiliary communications error”, setting Bit 5 of global status register X:\$000006.

I79 must be set greater than 0 if any auxiliary communications is desired with a MACRO Station. A value of 32 is suggested. If a value of I79 greater than 0 has been saved into PMAC’s non-volatile memory, then at subsequent power-up/resets, bit 14 of I70 is set to 0, the node-14 broadcast bit (bit 14 of I6840) is set to 1, and activation bit for node 14 (bit 14 of I6841) is set to

1, regardless of the value saved for these variables. This reserves Node 14 of MACRO IC 0 for the Type 1 Master/Master Auxiliary Communications.

I80, I81, I82: MACRO Ring Check Period and Limits

If I80 is set to a value greater than zero, Turbo PMAC will automatically monitor for MACRO ring breaks or repeated MACRO communications errors. A non-zero value sets the error detection cycle time in Turbo PMAC servo cycles. Turbo PMAC checks to see that “sync node” packets (see I6840 and I6841) are received regularly, and that there have not been regular communications errors.

The limits for these checks can be set by the user with variables I81 and I82. If less than I82 sync node packets have been received and detected during this time interval, or if I81 or more ring communications errors have been detected in this interval, Turbo PMAC will assume a major ring problem, and all motors will be shut down. Turbo PMAC will set the global status bit “Ring Error” (bit 4 of X:\$000006) as an indication of this error.

Turbo PMAC looks for receipt of sync node packets and ring communications errors once per real-time interrupt – every (I8 + 1) servo cycles). The time interval set by I80 must be large enough that I82 real-time interrupts in PMAC can always execute within the time interval, or false ring errors will be detected. Remember that long motion program calculations can cause “skips” in the real-time interrupt. Typically values of I80 setting a time interval of about 20 milliseconds are used. I80 can be set according to the formula:

$$I80 = \text{Desired cycle time (msec)} * \text{Servo update frequency (kHz)}$$

For example, with the default servo update frequency of 2.26 kHz, to get a ring check cycle interval of 20 msec, I80 would be set to $20 * 2.26 \cong 45$.

MACRO Node Addresses

The MACRO ring operates by copying registers at high speed across the ring. Therefore, the each Turbo PMAC2 master controller on the ring communicates with its slave stations by reading from and writing to registers in its own address space. MACRO hardware automatically handles the data transfers across the ring.

Starting in Turbo firmware version 1.936, the base addresses of the up to 4 MACRO ICs must be specified in I20 – I23, for MACRO IC 0 – 3 respectively. Before this the base addresses were fixed at \$078400, \$079400, \$07A400, and \$07B400, respectively. Only UMAC Turbo systems can support any other configuration, and only rarely will another configuration be used.

The following table gives the addresses of the MACRO ring registers for Turbo PMAC2 controllers. (Note that it is possible, although unlikely, to have other addresses in a UMAC Turbo system. In these systems, the 4th digit does not have to be ‘4’; it can also take the values ‘5’, ‘6’, and ‘7’.)

Register Addresses for MACRO IC 0 with I20=\$078400 (default)

	Turbo PMAC2	Addresses:	MACRO IC 0	
Node #	Reg. 0	Reg. 1	Reg. 2	Reg. 3
0	Y:\$078420	Y:\$078421	Y:\$078422	Y:\$078423
1	Y:\$078424	Y:\$078425	Y:\$078426	Y:\$078427
2	X:\$078420	X:\$078421	X:\$078422	X:\$078423
3	X:\$078424	X:\$078425	X:\$078426	X:\$078427
4	Y:\$078428	Y:\$078429	Y:\$07842A	Y:\$07842B
5	Y:\$07842C	Y:\$07842D	Y:\$07842E	Y:\$07842F
6	X:\$078428	X:\$078429	X:\$07842A	X:\$07842B
7	X:\$07842C	X:\$07842D	X:\$07842E	X:\$07842F
8	Y:\$078430	Y:\$078431	Y:\$078432	Y:\$078433
9	Y:\$078434	Y:\$078435	Y:\$078436	Y:\$078437
10	X:\$078430	X:\$078431	X:\$078432	X:\$078433
11	X:\$078434	X:\$078435	X:\$078436	X:\$078437
12	Y:\$078438	Y:\$078439	Y:\$07843A	Y:\$07843B
13	Y:\$07843C	Y:\$07843D	Y:\$07843E	Y:\$07843F
14	X:\$078438	X:\$078439	X:\$07843A	X:\$07843B
15	X:\$07843C	X:\$07843D	X:\$07843E	X:\$07843F

Register Addresses for MACRO IC 1 with I21=\$079400 (default)

	Turbo PMAC2	Addresses:	MACRO IC 1	
Node #	Reg. 0	Reg. 1	Reg. 2	Reg. 3
0	Y:\$079420	Y:\$079421	Y:\$079422	Y:\$079423
1	Y:\$079424	Y:\$079425	Y:\$079426	Y:\$079427
2	X:\$079420	X:\$079421	X:\$079422	X:\$079423
3	X:\$079424	X:\$079425	X:\$079426	X:\$079427
4	Y:\$079428	Y:\$079429	Y:\$07942A	Y:\$07942B
5	Y:\$07942C	Y:\$07942D	Y:\$07942E	Y:\$07942F
6	X:\$079428	X:\$079429	X:\$07942A	X:\$07942B
7	X:\$07942C	X:\$07942D	X:\$07942E	X:\$07942F
8	Y:\$079430	Y:\$079431	Y:\$079432	Y:\$079433
9	Y:\$079434	Y:\$079435	Y:\$079436	Y:\$079437
10	X:\$079430	X:\$079431	X:\$079432	X:\$079433
11	X:\$079434	X:\$079435	X:\$079436	X:\$079437
12	Y:\$079438	Y:\$079439	Y:\$07943A	Y:\$07943B
13	Y:\$07943C	Y:\$07943D	Y:\$07943E	Y:\$07943F
14	X:\$079438	X:\$079439	X:\$07943A	X:\$07943B
15	X:\$07943C	X:\$07943D	X:\$07943E	X:\$07943F

Register Addresses for MACRO IC 2 with I22=\$07A400 (default)

	Turbo PMA2	Addresses:	MACRO IC 2	
Node #	Reg. 0	Reg. 1	Reg. 2	Reg. 3
0	Y:\$07A420	Y:\$07A421	Y:\$07A422	Y:\$07A423
1	Y:\$07A424	Y:\$07A425	Y:\$07A426	Y:\$07A427
2	X:\$07A420	X:\$07A421	X:\$07A422	X:\$07A423
3	X:\$07A424	X:\$07A425	X:\$07A426	X:\$07A427
4	Y:\$07A428	Y:\$07A429	Y:\$07A42A	Y:\$07A42B
5	Y:\$07A42C	Y:\$07A42D	Y:\$07A42E	Y:\$07A42F
6	X:\$07A428	X:\$07A429	X:\$07A42A	X:\$07A42B
7	X:\$07A42C	X:\$07A42D	X:\$07A42E	X:\$07A42F
8	Y:\$07A430	Y:\$07A431	Y:\$07A432	Y:\$07A433
9	Y:\$07A434	Y:\$07A435	Y:\$07A436	Y:\$07A437
10	X:\$07A430	X:\$07A431	X:\$07A432	X:\$07A433
11	X:\$07A434	X:\$07A435	X:\$07A436	X:\$07A437
12	Y:\$07A438	Y:\$07A439	Y:\$07A43A	Y:\$07A43B
13	Y:\$07A43C	Y:\$07A43D	Y:\$07A43E	Y:\$07A43F
14	X:\$07A438	X:\$07A439	X:\$07A43A	X:\$07A43B
15	X:\$07A43C	X:\$07A43D	X:\$07A43E	X:\$07A43F

Register Addresses for MACRO IC 3 with I23=\$07B400 (default)

	Turbo PMA2	Addresses:	MACRO IC 3	
Node #	Reg. 0	Reg. 1	Reg. 2	Reg. 3
0	Y:\$07B420	Y:\$07B421	Y:\$07B422	Y:\$07B423
1	Y:\$07B424	Y:\$07B425	Y:\$07B426	Y:\$07B427
2	X:\$07B420	X:\$07B421	X:\$07B422	X:\$07B423
3	X:\$07B424	X:\$07B425	X:\$07B426	X:\$07B427
4	Y:\$07B428	Y:\$07B429	Y:\$07B42A	Y:\$07B42B
5	Y:\$07B42C	Y:\$07B42D	Y:\$07B42E	Y:\$07B42F
6	X:\$07B428	X:\$07B429	X:\$07B42A	X:\$07B42B
7	X:\$07B42C	X:\$07B42D	X:\$07B42E	X:\$07B42F
8	Y:\$07B430	Y:\$07B431	Y:\$07B432	Y:\$07B433
9	Y:\$07B434	Y:\$07B435	Y:\$07B436	Y:\$07B437
10	X:\$07B430	X:\$07B431	X:\$07B432	X:\$07B433
11	X:\$07B434	X:\$07B435	X:\$07B436	X:\$07B437
12	Y:\$07B438	Y:\$07B439	Y:\$07B43A	Y:\$07B43B
13	Y:\$07B43C	Y:\$07B43D	Y:\$07B43E	Y:\$07B43F
14	X:\$07B438	X:\$07B439	X:\$07B43A	X:\$07B43B
15	X:\$07B43C	X:\$07B43D	X:\$07B43E	X:\$07B43F

Note: With the MACRO station, only nodes that map into Turbo PMA2 “Y” registers (0, 1, 4, 5, 8, 9, 12, and 13) can be used for servo control. These nodes are unshaded in the above table. The nodes that map into “X” registers (2, 3, 6, 7, 10, 11, and 14) can be used for I/O control. Node 15 is reserved for “Type 1” auxiliary communications. Node 14 is often reserved for “broadcast” communications.

Turbo PMAC2 Conversion Table Setup

Turbo PMAC2 processes the raw feedback data it receives through an “encoder conversion table” before the servo loop uses the data for feedback. This table permits various techniques, such as “1/T” extension of encoder data, to refine the feedback values. However, when the 3U MACRO Station is used to provide the feedback, the Station has its own encoder conversion table to do the refinement before the data is sent across the ring. Therefore, all that the PMAC’s encoder conversion table must do is a simple copying operation.

The encoder conversion table on Turbo PMAC uses I-variables I8000 through I8191. I8000 represents the first line of the first entry in the table. Each entry in the table produces one feedback value. The entry can occupy one, two, or three lines.

Position feedback data for a node from a 3U MACRO station appears in the 24-bit Register 0 for the node. The least significant bit of the register represents 1/32 of a count (i.e. there are 5 bits of fraction).

To process this data for the servo loop (position and/or velocity loop feedback), the Turbo PMAC’s conversion table will treat the data as a “parallel” Y word, with no filtering (MACRO provides error detection). This makes bits 20 – 23 of the first line of the entry (the first hex digit) equal to \$2. The conversion will be “unshifted”, because the conversion result is also expected to have its LSB represent 1/32 of a count. This makes bit 19 of the first line equal to 1. Bits 0 – 18 contain the 19-bit address of the MACRO node’s register 0 (\$7x4yy, where ‘x’ varies with the MACRO IC, and ‘yy’ varies with the node number). This makes the line equal to \$2Fx4yy.

The second line of the entry (the next I-variable) specifies the bit width of the source register in bits 12 – 23 (the first three hex digits) and the starting bit number in bits 0 – 11 (the last three hex digits). Because position feedback in Register 0 is a 24-bit value starting at bit 0, this line should be \$018000, where \$018 specifies the 24-bit width, and \$000 specifies the bit-0 starting point.

The default conversion table in Turbo PMAC2 Ultralite controllers processes the position feedback registers of the eight servo nodes of MACRO IC 0. This yields the values in the following table.

Turbo PMAC2 Ultralite Defaults

I-Var.	Setting	Meaning	I-Var.	Setting	Meaning
I8000	\$2F8420	MACRO Node 0 Reg 0 Read	I8008	\$2F8430	MACRO Node 8 Reg 0 Read
I8001	\$018000	24 bits, bit 0 LSB	I8009	\$018000	24 bits, bit 0 LSB
I8002	\$2F8424	MACRO Node 1 Reg 0 Read	I8010	\$2F8434	MACRO Node 9 Reg 0 Read
I8003	\$018000	24 bits, bit 0 LSB	I8011	\$018000	24 bits, bit 0 LSB
I8004	\$2F8428	MACRO Node 4 Reg 0 Read	I8012	\$2F8438	MACRO Node 12 Reg 0 Read
I8005	\$018000	24 bits, bit 0 LSB	I8013	\$018000	24 bits, bit 0 LSB
I8006	\$2F842C	MACRO Node 5 Reg 0 Read	I8014	\$2F843C	MACRO Node 13 Reg 0 Read
I8007	\$018000	24 bits, bit 0 LSB	I8015	\$018000	24 bits, bit 0 LSB
I8016 - I8191 = 0					

The following table contains the entry first line for each servo node Register 0 for all MACRO ICs (with the addresses specified by I20 – I23 at their default values). Remember that the second line of the entry should always be \$018000.

Entries for Type 1 MACRO Position Feedback Registers

Register	First Line Value	Register	First Line Value
MACRO IC 0 Node 0 Reg. 0	\$2F8420	MACRO IC 2 Node 0 Reg. 0	\$2FA420
MACRO IC 0 Node 1 Reg. 0	\$2F8424	MACRO IC 2 Node 1 Reg. 0	\$2FA424
MACRO IC 0 Node 4 Reg. 0	\$2F8428	MACRO IC 2 Node 4 Reg. 0	\$2FA428
MACRO IC 0 Node 5 Reg. 0	\$2F842C	MACRO IC 2 Node 5 Reg. 0	\$2FA42C
MACRO IC 0 Node 8 Reg. 0	\$2F8430	MACRO IC 2 Node 8 Reg. 0	\$2FA430
MACRO IC 0 Node 9 Reg. 0	\$2F8434	MACRO IC 2 Node 9 Reg. 0	\$2FA434
MACRO IC 0 Node 12 Reg. 0	\$2F8438	MACRO IC 2 Node 12 Reg. 0	\$2FA438
MACRO IC 0 Node 13 Reg. 0	\$2F843C	MACRO IC 2 Node 13 Reg. 0	\$2FA43C
MACRO IC 1 Node 0 Reg. 0	\$2F9420	MACRO IC 3 Node 0 Reg. 0	\$2FB420
MACRO IC 1 Node 1 Reg. 0	\$2F9424	MACRO IC 3 Node 1 Reg. 0	\$2FB424
MACRO IC 1 Node 4 Reg. 0	\$2F9428	MACRO IC 3 Node 4 Reg. 0	\$2FB428
MACRO IC 1 Node 5 Reg. 0	\$2F942C	MACRO IC 3 Node 5 Reg. 0	\$2FB42C
MACRO IC 1 Node 8 Reg. 0	\$2F9430	MACRO IC 3 Node 8 Reg. 0	\$2FB430
MACRO IC 1 Node 9 Reg. 0	\$2F9434	MACRO IC 3 Node 9 Reg. 0	\$2FB434
MACRO IC 1 Node 12 Reg. 0	\$2F9438	MACRO IC 3 Node 12 Reg. 0	\$2FB438
MACRO IC 1 Node 13 Reg. 0	\$2F943C	MACRO IC 3 Node 13 Reg. 0	\$2FB43C

If Turbo PMAC2 is doing the commutation for the motor, it is best to use the “previous phase” position register in RAM as the servo feedback register. The commutation algorithm has already read the raw position data from the MACRO ring and copied it into this register, storing it for calculations in its next cycle. Using this register in the conversion table ensures that the servo algorithm uses the same position that the commutation used, even if new data has started coming in from the MACRO ring for the next cycle.

The following table lists the conversion table entries to use these registers. Remember that the second line of the entry should always be \$018000.

Entries for Motor Previous Phase Position Registers

Register	First Line Value	Register	First Line Value
Motor #1 Previous Phase Pos.	\$2800B2	Motor #17 Previous Phase Pos.	\$2808B2
Motor #2 Previous Phase Pos.	\$280132	Motor #18 Previous Phase Pos.	\$280932
Motor #3 Previous Phase Pos.	\$2801B2	Motor #19 Previous Phase Pos.	\$2809B2
Motor #4 Previous Phase Pos.	\$280232	Motor #20 Previous Phase Pos.	\$280A32
Motor #5 Previous Phase Pos.	\$2802B2	Motor #21 Previous Phase Pos.	\$280AB2
Motor #6 Previous Phase Pos.	\$280332	Motor #22 Previous Phase Pos.	\$280B32
Motor #7 Previous Phase Pos.	\$2803B2	Motor #23 Previous Phase Pos.	\$280BB2
Motor #8 Previous Phase Pos.	\$280432	Motor #24 Previous Phase Pos.	\$280C32
Motor #9 Previous Phase Pos.	\$2804B2	Motor #25 Previous Phase Pos.	\$280CB2
Motor #10 Previous Phase Pos.	\$280532	Motor #26 Previous Phase Pos.	\$280D32
Motor #11 Previous Phase Pos.	\$2805B2	Motor #27 Previous Phase Pos.	\$280DB2
Motor #12 Previous Phase Pos.	\$280632	Motor #28 Previous Phase Pos.	\$280E32
Motor #13 Previous Phase Pos.	\$2806B2	Motor #29 Previous Phase Pos.	\$280EB2
Motor #14 Previous Phase Pos.	\$280732	Motor #30 Previous Phase Pos.	\$280F32
Motor #15 Previous Phase Pos.	\$2807B2	Motor #31 Previous Phase Pos.	\$280FB2
Motor #16 Previous Phase Pos.	\$280832	Motor #32 Previous Phase Pos.	\$281032

Sometimes the conversion table will process data sent back to Turbo PMAC2 through “I/O” nodes, which are mapped into Turbo PMAC2 as X-registers. This is often done in cases of dual feedback or “loop-around-loop” configurations. Because these I/O nodes use X-registers instead of Y-registers, they use the \$6 conversion method (X/Y data) instead of the \$2 conversion method (Y data only), and specify a 24-bit offset in the second line of the entry

The following table shows entries for processing the data in the 24-bit register 0 of the first six I/O nodes for each MACRO IC.

Entries for MACRO I/O Node Register 0

Register	First Line Value	Register	First Line Value
MACRO IC 0 Node 2 Reg. 0	\$6F8420	MACRO IC 2 Node 2 Reg. 0	\$6FA420
MACRO IC 0 Node 3 Reg. 0	\$6F8424	MACRO IC 2 Node 3 Reg. 0	\$6FA424
MACRO IC 0 Node 6 Reg. 0	\$6F8428	MACRO IC 2 Node 6 Reg. 0	\$6FA428
MACRO IC 0 Node 7 Reg. 0	\$6F842C	MACRO IC 2 Node 7 Reg. 0	\$6FA42C
MACRO IC 0 Node 10 Reg. 0	\$6F8430	MACRO IC 2 Node 10 Reg. 0	\$6FA430
MACRO IC 0 Node 11 Reg. 0	\$6F8434	MACRO IC 2 Node 11 Reg. 0	\$6FA434
MACRO IC 1 Node 2 Reg. 0	\$6F9420	MACRO IC 3 Node 2 Reg. 0	\$6FB420
MACRO IC 1 Node 3 Reg. 0	\$6F9424	MACRO IC 3 Node 3 Reg. 0	\$6FB424
MACRO IC 1 Node 6 Reg. 0	\$6F9428	MACRO IC 3 Node 6 Reg. 0	\$6FB428
MACRO IC 1 Node 7 Reg. 0	\$6F942C	MACRO IC 3 Node 7 Reg. 0	\$6FB42C
MACRO IC 1 Node 10 Reg. 0	\$6F9430	MACRO IC 3 Node 10 Reg. 0	\$6FB430
MACRO IC 1 Node 11 Reg. 0	\$6F9434	MACRO IC 3 Node 11 Reg. 0	\$6FB434
The second line of one of these entries is \$018018. The first “018” specifies a 24-bit width. The second “018” specifies a 24-bit offset from the Y-register’s bit 0, which puts the least significant bit used at the X-register’s bit 0.			

Turbo PMAC2 Motor I-Variables

The following section lists Motor setup variables that have particular considerations when using MACRO Stations.

Ixx01: Commutation Enable

Ixx01 specifies whether Turbo PMAC2 performs commutation for Motor xx, and whether it uses ‘X’ or ‘Y’ registers. Only ‘Y’ registers are used when communicating to a MACRO Station over the ring.

If Turbo PMAC2 is not performing commutation for Motor xx, Ixx01 should be set to 0 (bit 0 = 0 specifies no commutation algorithm, bit 1 = 0 specifies the single output to the ‘Y’ register whose address is set by Ixx02).

If Turbo PMAC2 is performing commutation for Motor xx over the MACRO ring, with or without digital current-loop closure, Ixx01 should be set to 3 (bit 0 = 1 specifies commutation, bit 1 = 1 specifies commutation feedback from the ‘Y’ register whose address is set by Ixx83).

Ixx02: Command Output Address

Ixx02 specifies the address of the (first) register where Turbo PMAC2 writes the command output value(s) for Motor xx. In the MACRO Type 1 protocol, this is Register 0 of a MACRO servo node, regardless of the output mode (velocity, torque, phase current, or phase voltage).

The default values of Ixx02 for Turbo PMAC2 Ultralite boards specify these registers for each servo node of each MACRO IC. These are listed in the following table:

Turbo PMAC2 Ultralite Ixx02 Defaults

Ixx02	Value	Register	Ixx02	Value	Register
I102	\$078420	MACRO IC 0 Node 0 Reg. 0	I1702	\$07A420	MACRO IC 2 Node 0 Reg. 0
I202	\$078424	MACRO IC 0 Node 1 Reg. 0	I1802	\$07A424	MACRO IC 2 Node 1 Reg. 0
I302	\$078428	MACRO IC 0 Node 4 Reg. 0	I1902	\$07A428	MACRO IC 2 Node 4 Reg. 0
I402	\$07842C	MACRO IC 0 Node 5 Reg. 0	I2002	\$07A42C	MACRO IC 2 Node 5 Reg. 0
I502	\$078430	MACRO IC 0 Node 8 Reg. 0	I2102	\$07A430	MACRO IC 2 Node 8 Reg. 0
I602	\$078434	MACRO IC 0 Node 9 Reg. 0	I2202	\$07A434	MACRO IC 2 Node 9 Reg. 0
I702	\$078438	MACRO IC 0 Node 12 Reg. 0	I2302	\$07A438	MACRO IC 2 Node 12 Reg. 0
I802	\$07843C	MACRO IC 0 Node 13 Reg. 0	I2402	\$07A43C	MACRO IC 2 Node 13 Reg. 0
I902	\$079420	MACRO IC 1 Node 0 Reg. 0	I2502	\$07B420	MACRO IC 3 Node 0 Reg. 0
I1002	\$079424	MACRO IC 1 Node 1 Reg. 0	I2602	\$07B424	MACRO IC 3 Node 1 Reg. 0
I1102	\$079428	MACRO IC 1 Node 4 Reg. 0	I2702	\$07B428	MACRO IC 3 Node 4 Reg. 0
I1202	\$07942C	MACRO IC 1 Node 5 Reg. 0	I2802	\$07B42C	MACRO IC 3 Node 5 Reg. 0
I1302	\$079430	MACRO IC 1 Node 8 Reg. 0	I2902	\$07B430	MACRO IC 3 Node 8 Reg. 0
I1402	\$079434	MACRO IC 1 Node 9 Reg. 0	I3002	\$07B434	MACRO IC 3 Node 9 Reg. 0
I1502	\$079438	MACRO IC 1 Node 12 Reg. 0	I3102	\$07B438	MACRO IC 3 Node 12 Reg. 0
I1602	\$07943C	MACRO IC 1 Node 13 Reg. 0	I3202	\$07B43C	MACRO IC 3 Node 13 Reg. 0

If Motor xx is used to produce a pulse-and-direction output on the MACRO Station to control a traditional stepper drive or a “stepper-replacement” servo drive, the command output should be written to Register 2 of the servo node. In this mode, the proper values of Ixx02 are:

Ixx02	Value	Register	Ixx02	Value	Register
I102	\$078422	MACRO IC 0 Node 0 Reg. 2	I1702	\$07A422	MACRO IC 2 Node 0 Reg. 2
I202	\$078426	MACRO IC 0 Node 1 Reg. 2	I1802	\$07A426	MACRO IC 2 Node 1 Reg. 2
I302	\$07842A	MACRO IC 0 Node 4 Reg. 2	I1902	\$07A42A	MACRO IC 2 Node 4 Reg. 2
I402	\$07842E	MACRO IC 0 Node 5 Reg. 2	I2002	\$07A42E	MACRO IC 2 Node 5 Reg. 2
I502	\$078432	MACRO IC 0 Node 8 Reg. 2	I2102	\$07A432	MACRO IC 2 Node 8 Reg. 2
I602	\$078436	MACRO IC 0 Node 9 Reg. 2	I2202	\$07A436	MACRO IC 2 Node 9 Reg. 2
I702	\$07843A	MACRO IC 0 Node 12 Reg. 2	I2302	\$07A43A	MACRO IC 2 Node 12 Reg. 2
I802	\$07843E	MACRO IC 0 Node 13 Reg. 2	I2402	\$07A43E	MACRO IC 2 Node 13 Reg. 2
I902	\$079422	MACRO IC 1 Node 0 Reg. 2	I2502	\$07B422	MACRO IC 3 Node 0 Reg. 2
I1002	\$079422	MACRO IC 1 Node 1 Reg. 2	I2602	\$07B426	MACRO IC 3 Node 1 Reg. 2
I1102	\$07942A	MACRO IC 1 Node 4 Reg. 2	I2702	\$07B42A	MACRO IC 3 Node 4 Reg. 2
I1202	\$07942E	MACRO IC 1 Node 5 Reg. 2	I2802	\$07B42E	MACRO IC 3 Node 5 Reg. 2
I1302	\$079432	MACRO IC 1 Node 8 Reg. 2	I2902	\$07B432	MACRO IC 3 Node 8 Reg. 2
I1402	\$079436	MACRO IC 1 Node 9 Reg. 2	I3002	\$07B436	MACRO IC 3 Node 9 Reg. 2
I1502	\$07943A	MACRO IC 1 Node 12 Reg. 2	I3102	\$07B43A	MACRO IC 3 Node 12 Reg. 2
I1602	\$07943E	MACRO IC 1 Node 13 Reg. 2	I3202	\$07B43E	MACRO IC 3 Node 13 Reg. 2

Ixx03, Ixx04: Feedback Address

Ixx03 and Ixx04 specify the addresses of the registers that Turbo PMAC2 reads to get its position-loop and velocity-loop feedback values, respectively. Almost always, this is a “result” register in the encoder conversion table. Unless the motor uses dual feedback, the values of Ixx03 and Ixx04 are the same, which means the same sensor is used for both position-loop and velocity-loop feedback.

Note:

The automatic servo node functions on a MACRO Station do not support dual feedback in a single node. For dual feedback, either a second servo node must be used, or one of the feedback values (usually the velocity-loop feedback position) must be sent back to the Turbo PMAC2 as an “I/O” value.

These variables should contain the address of the last line of the entry in the conversion table. With either of the conversion tables suggested above, this would be the second line of each entry: lines 1, 3, 5, 7, etc. of the conversion table. The default values for the Turbo PMAC2 Ultralite boards listed below contain the addresses of these registers.

Turbo PMAC2 Ultralite Ixx03 Defaults

Ixx03	Value	Register	Ixx03	Value	Register
I103	\$003502	Conversion Table Line 1	I1703	\$003522	Conversion Table Line 33
I203	\$003504	Conversion Table Line 3	I1803	\$003524	Conversion Table Line 35
I303	\$003506	Conversion Table Line 5	I1903	\$003526	Conversion Table Line 37
I403	\$003508	Conversion Table Line 7	I2003	\$003528	Conversion Table Line 39
I503	\$00350A	Conversion Table Line 9	I2103	\$00352A	Conversion Table Line 41
I603	\$00350C	Conversion Table Line 11	I2203	\$00352C	Conversion Table Line 43
I703	\$00350E	Conversion Table Line 13	I2303	\$00352E	Conversion Table Line 45
I803	\$003510	Conversion Table Line 15	I2403	\$003530	Conversion Table Line 47
I903	\$003512	Conversion Table Line 17	I2503	\$003532	Conversion Table Line 49
I1003	\$003514	Conversion Table Line 19	I2603	\$003534	Conversion Table Line 51
I1103	\$003516	Conversion Table Line 21	I2703	\$003536	Conversion Table Line 53
I1203	\$003518	Conversion Table Line 23	I2803	\$003538	Conversion Table Line 55
I1303	\$00351A	Conversion Table Line 25	I2903	\$00353A	Conversion Table Line 57
I1403	\$00351C	Conversion Table Line 27	I3003	\$00353C	Conversion Table Line 59
I1503	\$00351E	Conversion Table Line 29	I3103	\$00353E	Conversion Table Line 61
I1603	\$003520	Conversion Table Line 31	I3203	\$003540	Conversion Table Line 63

Ixx10, Ixx95: Absolute Position Address and Format

Ixx10 and Ixx95 permit an automatic read of an absolute position sensor at power-on/reset and/or on a subsequent \$* or \$\$* command. If Ixx10 is set to 0, the power-on/reset position for the motor will be considered to be 0, regardless of the type of sensor used. If Ixx10 is set to a value greater than zero, an absolute position can be read, with Ixx10 specifying an address for reading this value.

When reading absolute position over the MACRO ring, the address contained in Ixx10 is specified in the format \$0000mn, where ‘m’ is the MACRO IC number (0, 1, 2, or 3) and ‘n’ is the node number (0, 1, 4, 5, 8, 9, 12, or 13). If both ‘m’ and ‘n’ are 0, the 4th hex digit of Ixx10 should be set to 1 (Ixx10 = \$000100) to keep the total value of Ixx10 greater than zero and activate the absolute position read.

The following table shows the required values of Ixx10 for all of the MACRO nodes that can be used.

Note:

MACRO IC 0 Node 0 uses an Ixx10 value of \$000100, because Ixx10=0 disables the absolute position read function.

Ixx10 for MACRO Absolute Position Reads
(Ixx95=\$720000 - \$740000, \$F20000 - \$F40000)

Addresses are MACRO Node Numbers

MACRO Node Number	Ixx10 for MACRO IC 0	Ixx10 for MACRO IC 1	Ixx10 for MACRO IC 2	Ixx10 for MACRO IC 3
0	\$000100	\$000010	\$000020	\$000030
1	\$000001	\$000011	\$000021	\$000031
4	\$000004	\$000014	\$000024	\$000034
5	\$000005	\$000015	\$000025	\$000035
8	\$000008	\$000018	\$000028	\$000038
9	\$000009	\$000019	\$000029	\$000039
12	\$00000C	\$00001C	\$00002C	\$00003C
13	\$00000D	\$00001D	\$00002D	\$00003D

There are specific settings of Turbo PMAC2's Ixx95 for each type of MACRO sensor interface. The 3U MACRO Station has a corresponding variable MI11x for each node that must be set.

3U MACRO Station Feedback Type	Turbo Ixx95 (Unsigned)	Station MI11x (Unsigned)	Turbo Ixx95 (Signed)	Station MI11x (Signed)
ACC-8D Opt 7 Resolver/Digital Converter	\$730000	\$00xxxx - \$07xxxx	\$F30000	\$80xxxx - \$87xxxx
ACC-8D Opt 9 Yaskawa Absolute Encoder Converter	\$720000	\$71xxxx - \$72xxxx	\$F20000	\$F1xxxx - \$F2xxxx
ACC-49 Sanyo 26-bit Absolute Encoder Converter	\$740000	\$32xxxx	\$F40000	\$B2xxxx
ACC-28B/E Analog/Digital Converter	\$740000	\$31xxxx	--	--
ACC-1E/6E/36E/59E A/D Converter (low 12 bits)	\$740000	\$0Cxxxx	\$F40000	\$8Cxxxx
ACC-1E/6E/36E/59E A/D Converter (high 12 bits)	\$740000	\$33xxxx	\$F40000	\$B3xxxx
MACRO Station MLDT Input	\$740000	\$17xxxx	--	--
MACRO Station Parallel Input (from 24-bit word	\$740000	\$08xxxx - \$2Axxxx	\$F40000	\$88xxxx - \$AAxxxx
ACC-3E/14E Parallel Input from 2 consecutive lower bytes	\$740000	\$2Bxxxx	\$F40000	\$ABxxxx
ACC-3E Parallel Input from 2 consecutive middle bytes	\$740000	\$2Cxxxx	\$F40000	\$ACxxxx
ACC-3E Parallel Input from 2 consecutive upper bytes	\$740000	\$2Dxxxx	\$F40000	\$ADxxxx
ACC-3E/14E Parallel Input from 2 consecutive lower bytes	\$740000	\$2Exxxx	\$F40000	\$AExxxx
ACC-3E Parallel Input from 2 consecutive middle bytes	\$740000	\$2Fxxxx	\$F40000	\$AFxxxx
ACC-3E Parallel Input from 2 consecutive upper bytes	\$740000	\$30xxxx	\$F40000	\$B0xxxx

When Turbo PMAC2 has Ixx10 and Ixx95 set to get absolute position over MACRO, it executes a station auxiliary read command **MS{node},MI920** to request the absolute position from the 3U MACRO Station. The station then references its own MI11x value to determine the type, format, and address of the data to be read. The data is returned to Turbo PMAC2 with up to 42 bits of data, sign extended to 46 bits. Note that the Turbo PMAC's Ixx95 and the Station's MI11x must agree as to whether the data is signed or unsigned.

Bit 48 is a Ready/Busy handshake bit and Bit 47 is a pass/fail status bit. If Bit 47 is set, the upper 24 bits of the 48 bits returned are an error word and are stored in X:\$00320E of the PMAC/PMAC2.

Ixx25, Ixx24: Flag Address and Mode

If the auxiliary functions for Node n of MACRO IC 0, 1, 2, or 3 have been enabled by setting Bit n of I70, I72, I74, or I76, respectively, to 1, the flag information in Register 3 for the node is automatically copied to and from PMAC RAM register \$00347 n , \$00357 n , \$00367 n , or \$00377 n , respectively. In this case, Ixx25 should specify the address of the RAM copy, not the actual MACRO interface register.

The following table lists the default values for Ixx25 on a Turbo PMAC2 Ultralite, which shows the address of the RAM copy register for each MACRO servo node:

Turbo PMAC2 Ultralite Ixx25 Defaults

Ixx25	Value	Register	Ixx25	Value	Register
I125	\$003440	MACRO Flag Register Set 0	I1725	\$003460	MACRO Flag Register Set 32
I225	\$003441	MACRO Flag Register Set 1	I1825	\$003461	MACRO Flag Register Set 33
I325	\$003444	MACRO Flag Register Set 4	I1925	\$003464	MACRO Flag Register Set 36
I425	\$003445	MACRO Flag Register Set 5	I2025	\$003465	MACRO Flag Register Set 37
I525	\$003448	MACRO Flag Register Set 8	I2125	\$003468	MACRO Flag Register Set 40
I625	\$003449	MACRO Flag Register Set 9	I2225	\$003469	MACRO Flag Register Set 41
I725	\$00344C	MACRO Flag Register Set 12	I2325	\$00346C	MACRO Flag Register Set 44
I825	\$00344D	MACRO Flag Register Set 13	I2425	\$00346D	MACRO Flag Register Set 45
I925	\$003450	MACRO Flag Register Set 16	I2525	\$003470	MACRO Flag Register Set 48
I1025	\$003451	MACRO Flag Register Set 17	I2625	\$003471	MACRO Flag Register Set 49
I1125	\$003454	MACRO Flag Register Set 20	I2725	\$003474	MACRO Flag Register Set 52
I1225	\$003455	MACRO Flag Register Set 21	I2825	\$003475	MACRO Flag Register Set 53
I1325	\$003458	MACRO Flag Register Set 24	I2925	\$003478	MACRO Flag Register Set 56
I1425	\$003459	MACRO Flag Register Set 25	I3025	\$003479	MACRO Flag Register Set 57
I1525	\$00345C	MACRO Flag Register Set 28	I3125	\$00347C	MACRO Flag Register Set 60
I1625	\$00345D	MACRO Flag Register Set 29	I3225	\$00347D	MACRO Flag Register Set 61

Ixx24 specifies how the address in Ixx25 is to be used. Bit 0 of Ixx24 must be set to 1 to specify PMAC2-style flag arrangements, which are used in the MACRO protocol. Bit 18 of Ixx24 must be set to 1 to specify that the flags are sent and received across MACRO. Bit 23 of Ixx24, which specifies the polarity of the amplifier/node fault bit into the Turbo PMAC2, must be set to match the polarity defined in the Station with the appropriate bit of MI18. If the bit “ n ” of MI18, and bit 23 of Ixx24 are set to 0, a “low-true” fault (logical 0 means fault, regardless of the input voltage) is specified. If the bit “ n ” of MI18, and bit 23 or Ixx24 are set to 1, a “high-true” fault (logical 1 means fault) is specified

If no other bits of Ixx24 are set, the value of Ixx24 is \$040001 or \$840001. \$040001 is the default value for Ixx24 on Turbo PMAC2 Ultralite boards. Refer to the detailed description of Ixx24 in the Turbo PMAC Software Reference for descriptions of the other bits.

When Bit 18 of Ixx24 is set to 1, and bit n of I1000 is set to 1, then the Motor xx flag information is automatically copied between the holding registers at \$00344 n , \$00345 n , \$00346 n , or \$00347 n , and the MACRO interface registers for node n of MACRO IC 0, 1, 2, or 3, respectively, on the Turbo PMAC2. The command flags, such as amplifier enable, are held in the Y-register of \$0034 xn . The feedback flags, such as overtravel limits and amplifier fault, are held in the X-registers of \$0034 xn . Monitoring of flag values should use these holding registers in RAM, not the actual MACRO node registers.

The following tables show the locations of the individual flags in these registers:

Motor Command Flags: Y:\$0034xn for MACRO IC (x-4) Node n

Bit #	Function	Notes
0	Position Capture Prepare Flag	Must be set to 1 to prepare for hardware capture over ring; to 0 when done
1-7	(Not Used)	
8-10	(reserved for future use)	
11	Position Capture Enable Flag	Must be set to 1 to prepare for hardware capture over ring; to 0 when done
12	Node Position Reset Flag	
13	(reserved for future use)	
14	Amplifier Enabled	Command to Station
15-23	(reserved for future use)	

Motor Status Flags: X:\$0034xn for MACRO IC (x-4) Node n

Bit #	Function	Notes
0-7	(Not Used)	
8-10	(reserved for future use)	
11	Position Captured Flag	Latched from selected flag
12	Power-On Reset or Node Reset Occurred	
13	Ring Break Detected Elsewhere	
14	Amplifier Enabled	Status from Station
15	Amplifier/Node Shutdown Fault	1 is treated as shutdown if Ix25 bit 23 = 1; 0 if Ix25 bit 23 = 0
16	Home Flag (HOME) Input Value	
17	Positive Limit Flag (PLIM) Value	
18	Negative Limit Flag (MLIM) Value	
19	User Flag (USER) Input Value	
20	Flag W Input Value	
21	Flag V Input Value	
22	Flag U Input Value	
23	Flag T Input Value	

Ixx70, Ixx71: Commutation Cycle Size

If the Turbo PMAC2 is performing commutation for Motor xx, providing either 2 phase current commands (“sine-wave output”) or 3 PWM phase voltage commands (“direct PWM output”), the size of the commutation cycle is equal to Ixx71/Ixx70, normally expressed in encoder counts. Because the MACRO station provides position feedback in units of 1/32 count for both servo and commutation, the value of Ixx70 and Ixx71 must be set to provide a ratio 32 times the number of true counts in the commutation cycle.

For example, if the commutation cycle has 1000 encoder counts, Ixx70 could be set to 1 and Ixx71 could be set to 32,000.

Ixx75: Absolute Phase Position Offset

If Ixx81 (see below) is set to a value greater than 0, then PMAC will read an absolute sensor for power-on phase position. In this case it will use Ixx75 to determine the difference between the absolute sensor’s zero position and the phase commutation cycle’s zero position (unless Hall commutation sensors are used, in which case Ixx91 contains the initial offset information, which needs to be corrected later).

Normally, this position difference in Ixx75 is expressed in counts multiplied by Ixx70. However, when the absolute position is read from the position feedback register, as from a Yaskawa absolute encoder through an ACC-8D Opt 9 and the MACRO Station, then Ixx75 is expressed in units of 1/32 of a count multiplied by Ixx70.

Ixx81, Ixx91: Power-On Phase Position Address and Mode

Ixx81 permits an automatic read of an absolute position sensor for phase referencing of a synchronous motor commutated by PMAC. This read can be done automatically at power-on/reset (if Ixx80 = 1 or 3), or subsequently on the \$ or \$\$ command. If Ixx81 is set to 0, the power-on/reset phase position for the motor will be considered to be 0, regardless of the type of sensor used. If Ixx81 is set to a value greater than 0, Turbo PMAC2 will use the address or node specified by Ixx81 to read an absolute phase position, in a manner determined by Ixx91.

There are specific settings of Turbo PMAC2’s Ixx91 for each type of MACRO interface to the MACRO Station. The 3U MACRO Station has a corresponding variable MI11x for each node that must be set. Since the MACRO Station’s MI11x also affects the absolute servo position read by Ixx10 and Ixx95 on the Turbo PMAC2, and that position can be signed or unsigned, MI11x bit 23 specifies whether the absolute servo position is read as signed or unsigned. This bit does not matter for the purposes of absolute phase position, which is always treated as unsigned.

The following table shows the possible settings of Ixx81 and Ixx91, along with the required matching settings of MI11x, for the different types of absolute phase position formats supported:

Ixx81, Ixx91 Values for MACRO Station Absolute Feedback

3U MACRO Station Feedback Type	Ixx81 Value	Ixx91 Value	Station MI11x Bits 16-23
ACC-8D Opt 7 Resolver/Digital Converter	\$0000mn	\$730000	\$00-\$07 (\$80-\$87)
ACC-8D Opt 9 Yaskawa Absolute Encoder Converter	\$07x4yy	\$bb0000	See Note 1
ACC-49 Sanyo Absolute Encoder Converter	\$0000mn	\$740000	\$0D
ACC-28B/E Analog/Digital Converter	\$0000mn	\$740000	\$31
MACRO Station Hall Sensor Flag Input	\$0034xn	\$vv0000	See Note 2
ACC-1E/6E/36E/59E A/D Converter (low 12 bits)	\$0000mn	\$740000	\$0C (\$8C)
ACC-1E/6E/36E/59E A/D Converter (high 12 bits)	\$0000mn	\$740000	\$33 (\$B3)
MACRO Station Parallel Input	\$0000mn	\$740000	\$08-\$30 (\$88-\$B0)
MACRO Station MLDT Input	\$0000mn	\$740000	\$08-\$30 (\$88-\$B0)
ACC-3E/14E Parallel Input from 2 consecutive lower bytes	\$0000mn	\$740000	\$2B (\$AB)
ACC-3E Parallel Input from 2 consecutive middle bytes	\$0000mn	\$740000	\$2C (\$AC)
ACC-3E Parallel Input from 2 consecutive upper bytes	\$0000mn	\$740000	\$2D (\$AD)
ACC-3E/14E Parallel Input from 2 consecutive lower bytes	\$0000mn	\$740000	\$2E (\$AE)
ACC-3E Parallel Input from 2 consecutive middle bytes	\$0000mn	\$740000	\$2F (\$AF)
ACC-3E Parallel Input from 2 consecutive upper bytes	\$0000mn	\$740000	\$30 (\$B0)
‘m’ is the number of the MACRO IC used: 0, 1, 2, or 3 ‘n’ is the MACRO node number used for Motor xx: 0, 1, 4, 5, 8, 9, C(12), or D(13). ‘bb’ is the number of bits in a revolution of the encoder (e.g. 13 bits for 8192 counts) plus 5 (to account for the 5 fractional bits), expressed in hexadecimal format (e.g. for 8192 counts/rev, 13 + 5 = 18 = \$12) ‘\$07x4yy’ represents the address of the MACRO node’s Register 0, which contains the position information. ‘x’ is 8, 9, A, or B, for MACRO IC 0, 1, 2, or 3, respectively. ‘yy’ varies with the node number. ‘vv’ is a value from \$80 to \$FF representing the Hall sensor offset and direction.			

For purposes of absolute phase position, Turbo PMAC2 simply reads the encoder counter value in its own MACRO node, communicated automatically by the servo node functions. The MI11x setting is not used to obtain the phase position, but it will probably be set to \$71xxxx or \$F1xxxx for absolute servo position.

For purposes of absolute phase position, Turbo PMAC2 simply reads the hall sensor values in its own MACRO node, communicated automatically by the auxiliary servo node functions. The MI11x setting is not used here, but may be set to a non-zero value if an absolute servo position sensor is also used.

When Turbo PMAC2 has Ixx91 set to get absolute position over MACRO, it executes a station auxiliary read command **MS{node} ,MI920** to request the absolute position from the 3U MACRO Station. The station then references its own MI11x value to determine the type, format, and address of the data to be read. The data is returned to Turbo PMAC2 with up to 42 bits of data, sign extended to 46 bits. Bit 48 is a Ready/Busy handshake bit and Bit 47 is a pass/fail status bit. If Bit 47 is set, the upper 24 bits of the 48 bits returned form an word and are stored in X:\$00320E of the Turbo PMAC2.

Note:

With the Yaskawa absolute encoder format, and with the Hall commutation sensor format, the Turbo PMAC2 is not going directly to the MACRO Station for absolute phase position information. This information has already been copied into a Turbo PMAC2 register with another software function.

Ixx82: Current Loop Feedback Address

If the Turbo PMAC2 is being operated in direct PWM mode, Ixx82 must specify the address of the Phase B current feedback register. (If it is not being operated in direct PWM mode, Ixx82 must be set to 0.) When in direct PWM mode over MACRO, the Phase B current feedback value appears in the MACRO servo node's Register 2, so Ixx82 must contain the address of this register. The following table shows the typical values of Ixx82 in this mode, listing the address of Register 2 for each servo MACRO node.

Turbo PMAC2 Ultralite Ixx82 Typical Settings

Ixx82	Value	Register	Ixx82	Value	Register
I182	\$078422	MACRO IC 0 Node 0 Reg. 2	I1782	\$07A422	MACRO IC 2 Node 0 Reg. 2
I282	\$078426	MACRO IC 0 Node 1 Reg. 2	I1882	\$07A426	MACRO IC 2 Node 1 Reg. 2
I382	\$07842A	MACRO IC 0 Node 4 Reg. 2	I1982	\$07A42A	MACRO IC 2 Node 4 Reg. 2
I482	\$07842E	MACRO IC 0 Node 5 Reg. 2	I2082	\$07A42E	MACRO IC 2 Node 5 Reg. 2
I582	\$078432	MACRO IC 0 Node 8 Reg. 2	I2182	\$07A432	MACRO IC 2 Node 8 Reg. 2
I682	\$078436	MACRO IC 0 Node 9 Reg. 2	I2282	\$07A436	MACRO IC 2 Node 9 Reg. 2
I782	\$07843A	MACRO IC 0 Node 12 Reg. 2	I2382	\$07A43A	MACRO IC 2 Node 12 Reg. 2
I882	\$07843E	MACRO IC 0 Node 13 Reg. 2	I2482	\$07A43E	MACRO IC 2 Node 13 Reg. 2
I982	\$079422	MACRO IC 1 Node 0 Reg. 2	I2582	\$07B422	MACRO IC 3 Node 0 Reg. 2
I1082	\$079426	MACRO IC 1 Node 1 Reg. 2	I2682	\$07B426	MACRO IC 3 Node 1 Reg. 2
I1182	\$07942A	MACRO IC 1 Node 4 Reg. 2	I2782	\$07B42A	MACRO IC 3 Node 4 Reg. 2
I1282	\$07942E	MACRO IC 1 Node 5 Reg. 2	I2882	\$07B42E	MACRO IC 3 Node 5 Reg. 2
I1382	\$079432	MACRO IC 1 Node 8 Reg. 2	I2982	\$07B432	MACRO IC 3 Node 8 Reg. 2
I1482	\$079436	MACRO IC 1 Node 9 Reg. 2	I3082	\$07B436	MACRO IC 3 Node 9 Reg. 2
I1582	\$07943A	MACRO IC 1 Node 12 Reg. 2	I3182	\$07B43A	MACRO IC 3 Node 12 Reg. 2
I1682	\$07943E	MACRO IC 1 Node 13 Reg. 2	I3282	\$07B43E	MACRO IC 3 Node 13 Reg. 2

Ixx83: Commutation Feedback Address

If the Turbo PMAC2 is performing commutation for Motor xx (Ixx01 bit 0 = 1), providing either 2 phase current commands (“sine-wave output”) or 3 PWM phase voltage commands (“direct PWM”), Ixx83 must specify the address of the ongoing commutation position feedback.

When commutating over MACRO, the position feedback comes from Register 0 of the MACRO node. In this case, Ixx83 must contain the address of this MACRO node register. The following table contains the default Ixx83 values for Turbo PMAC2 Ultralite boards, listing the addresses of the position feedback registers for each MACRO servo node.

Turbo PMAC2 Ultralite Ixx83 Defaults

Ixx83	Value	Register	Ixx83	Value	Register
I183	\$078420	MACRO IC 0 Node 0 Reg. 0	I1783	\$07A420	MACRO IC 2 Node 0 Reg. 0
I283	\$078424	MACRO IC 0 Node 1 Reg. 0	I1883	\$07A424	MACRO IC 2 Node 1 Reg. 0
I383	\$078428	MACRO IC 0 Node 4 Reg. 0	I1983	\$07A428	MACRO IC 2 Node 4 Reg. 0
I483	\$07842C	MACRO IC 0 Node 5 Reg. 0	I2083	\$07A42C	MACRO IC 2 Node 5 Reg. 0
I583	\$078430	MACRO IC 0 Node 8 Reg. 0	I2183	\$07A430	MACRO IC 2 Node 8 Reg. 0
I683	\$078434	MACRO IC 0 Node 9 Reg. 0	I2283	\$07A434	MACRO IC 2 Node 9 Reg. 0
I783	\$078438	MACRO IC 0 Node 12 Reg. 0	I2383	\$07A438	MACRO IC 2 Node 12 Reg. 0
I883	\$07843C	MACRO IC 0 Node 13 Reg. 0	I2483	\$07A43C	MACRO IC 2 Node 13 Reg. 0
I983	\$079420	MACRO IC 1 Node 0 Reg. 0	I2583	\$07B420	MACRO IC 3 Node 0 Reg. 0
I1083	\$079424	MACRO IC 1 Node 1 Reg. 0	I2683	\$07B424	MACRO IC 3 Node 1 Reg. 0
I1183	\$079428	MACRO IC 1 Node 4 Reg. 0	I2783	\$07B428	MACRO IC 3 Node 4 Reg. 0
I1283	\$07942C	MACRO IC 1 Node 5 Reg. 0	I2883	\$07B42C	MACRO IC 3 Node 5 Reg. 0
I1383	\$079430	MACRO IC 1 Node 8 Reg. 0	I2983	\$07B430	MACRO IC 3 Node 8 Reg. 0
I1483	\$079434	MACRO IC 1 Node 9 Reg. 0	I3083	\$07B434	MACRO IC 3 Node 9 Reg. 0
I1583	\$079438	MACRO IC 1 Node 12 Reg. 0	I3183	\$07B438	MACRO IC 3 Node 12 Reg. 0
I1683	\$07943C	MACRO IC 1 Node 13 Reg. 0	I3283	\$07B43C	MACRO IC 3 Node 13 Reg. 0

Because these are all ‘Y’ addresses, bit 1 of Ixx01 must be set to 1. With bit 0 of Ixx01 set to 1 to enable commutation, the net value of Ixx01 is 3.

SOFTWARE SETUP OF 3U MACRO STATION

The software configuration of the 3U MACRO Station is accomplished through the setup of the Station's own variables. These "MI" (MACRO Initialization) variables on the station permit the user to configure the station for a particular application.

Note:

The 3U MACRO Station's initialization variables can either be referred to as "MI-variables" or "I-variables". This manual uses the "MI-variable" terminology to distinguish them from the PMAC's own I-variables.

Typically, the MI-variable setup for a 3U MACRO Station is accomplished through a special program, such as "Turbo Setup", which hides the actual PMAC commands from the user. However, these variables may be written to and read from in other applications using special PMAC commands.

Station Variable Read/Write Commands

The most common PMAC commands used for setup are the basic on-line MI-variable read and write commands. The syntax for the read command is:

MS{node #},MI{variable #}

where {node #} can be the number of any active node on the Station (usually that of the lowest active node) for most of the MI-variables, or the number of the individual node for one of the node-specific MI-variables (MI910 - MI939). {variable #} is the number of the Station MI-variable (0 - 1023). Sending this command to PMAC causes PMAC to send a request to the Station using the auxiliary communications channel on Node 15 (which must be active) for the value of the specified MI-variable. The Station then responds with the value, and PMAC reports the value to the host computer. For example:

```
MS0,MI992      ; Have PMAC request of Station with active node 0
                ; the value of MI992
6527           ; PMAC responds with the value it received from Station

MS1,MI910      ; Have PMAC request of Station Node 1 the value of MI910
7             ; PMAC responds with the value it received from Station
```

The syntax for the write command is

MS{node #},MI{variable #}={constant}

where {node #} can be the number of any active node on the Station (usually that of the lowest active node) for most of the MI-variables, or the number of the individual node for one of the node-specific MI-variables (MI910 - MI939). {variable #} is the number of the Station MI-variable (0 - 1023). {constant} is the numerical value to be assigned to the variable. Sending this command to PMAC causes PMAC to send a command to the Station using the auxiliary communications channel on Node 15 (which must be active) to assign the value to the specified MI-variable. For example:

```
MS0,MI992=3263 ; Have PMAC command Station with active node 0 to assign
                ; a value of 3263 to MI992
MS1,MI910=3    ; Have PMAC command Station Node 1 to assign a value of 3
                ; to MI910
```

Station Variable Copy Commands

It is also possible to copy values between 3U MACRO Station MI-variables and PMAC variables. This is done with MACRO Variable Copy commands, which can be used either as on-line commands, or as buffered program commands in background PLC programs PLC1-31 and PLCC1-31 (but not in PLC0, PLCC0, or motion programs, which execute in foreground).

The command that copies from a Station MI-variable to a PMAC variable (reading from the Station) is the **MSR** command. The syntax for the command is:

MSR{node #},MI{variable #},{PMAC Variable}

where {node #} can be the number of any active node on the Station (usually that of the lowest active node) for most of the MI-variables, or the number of the individual node for one of the node-specific MI-variables (MI910 - MI939). {variable #} is the number of the Station MI-variable (0 - 1023) from which the value is copied. {PMAC Variable} is the name of the variable on PMAC (e.g. P10) to which the value is copied. For example:

MSR0,MI984,P50 ; Copy from Station with active node 0 MI984 to PMAC P50

MSR1,MI922,P99 ; Copy from Station Node 1 MI922 to PMAC P99

The command that copies from a PMAC variable to a Station MI-variable (writing to the Station) is the **MSW** command. The syntax for the command is:

MSW{node #},MI{variable #},{PMAC Variable}

where {node #} can be the number of any active node on the Station (usually that of the lowest active node) for most of the MI-variables, or the number of the individual node for one of the node-specific MI-variables (MI910 - MI939). {variable #} is the number of the Station MI-variable (0 - 1023) to which the value is copied. {PMAC Variable} is the name of the variable on PMAC (e.g. P10) from which the value is copied. For example:

MSW0,MI992,I992 ; Copy from PMAC I992 to Station with active node 0 MI992

MSW1,MI925,P103 ; Copy from PMAC P103 to Station Node 1 MI925

Ring Control Setup Variables

Ring Update Frequency: MI992 and MI997 for the 3U MACRO Station control the phase frequency on the Station, which is the frequency at which the Station expects the ring to be updated. The actual ring update frequency is determined by the ring controller master; for best operation, the 3U MACRO Station should be set to the same frequency.

MI992 determines the “MaxPhase” clock frequency, from which the phase clock frequency is derived. The equation is

$$\text{MaxPhase Frequency (kHz)} = 117,964.8 / [2 * \text{MI992} + 3]$$

MI997 determines how the phase clock frequency is divided down from MaxPhase. The equation is

$$\text{Phase Frequency (kHz)} = \text{MaxPhase Frequency (kHz)} / (\text{MI997} + 1)$$

Generally, both the MaxPhase and Phase frequencies will be the same on the MACRO Station as they are on the PMAC2 controlling it. However, only the Phase frequency must be the same. Because the MaxPhase frequency on the MACRO Station also controls the PWM frequency for Channels 9 and 10 of the ACC-1E 2-Axis Interface Board, it may be desirable to have different MaxPhase frequencies on the Station and the PMAC2 board. This is permissible as long as the Phase frequencies are the same.

If the ring controller is a (non-Turbo) PMAC2 Ultralite, the following relationship should hold:

$$\{MACRO\ Station\} MI992 * (MI997 + 1) = I992 * (I997 + 1) \{PMAC2\ Ultralite\}$$

If the ring controller is a PMAC2 that is neither Turbo nor Ultralite, the following relationship should hold:

$$\{MACRO\ Station\} MI992 * (MI997 + 1) = I900 * (I901 + 1) \{PMAC2\}$$

If the ring controller is a Turbo PMAC2 Ultralite, or a UMAC Turbo with ACC-5E, the following relationship should hold:

$$\{MACRO\ Station\} MI992 * (MI997 + 1) = I6800 * (I6801 + 1) \{Turbo\ PMAC2\ Ultralite\}$$

If the ring controller is a Turbo PMAC2 that is not Ultralite, the following relationship should hold:

$$\{MACRO\ Station\} MI992 * (MI997 + 1) = I7000 * (I7001 + 1) \{Turbo\ PMAC2\}$$

Note:

Even if I7 is set greater than 0 on a Turbo PMAC2, so that the phasing tasks on the Turbo PMAC2 are not done every phase clock cycle, it is important that the actual phase clock frequencies themselves be the same on the Turbo PMAC2 and the MACRO Station.

Station Servo Clock Frequency: MI998 on a MACRO Station controls how the servo clock on the Station is derived from the Station's phase clock. The phase clock frequency is divided by (MI998 + 1) to obtain the phase clock. No software tasks on the station are performed on the servo clock (all are done on the phase clock), but key feedback registers, such as encoder position and timers, are latched by the servo clock. MI998 should always be set to 0 on a MACRO Station to make the servo clock frequency equal to the phase clock frequency, so that the software algorithms always have updated position information to use.

Additional Node Enabling & Disabling

If MACRO Station setup variables MI975 and MI976 are both set to 0 (the default values) at power-up/reset, only those MACRO servo nodes selected by rotary switch SW1 on the Station are enabled for ring communications. The following table lists which nodes are enabled for each SW1 setting:

Setting	Enabled Nodes	Setting	Enabled Nodes
0	0, 1, 4, 5	8	0, 1
1	8, 9, 12, 13	9	4, 5
2	0, 1	A (10)	8, 9
3	4, 5	B (11)	12, 13
4	8, 9	C (12)	0, 1, 4, 5, 8, 9
5	12, 13	D (13)	none
6	0, 1, 4, 5, 8, 9	E (14)	11 (I/O only)
7	0, 1, 4, 5, 8, 9, 12, 13	F (15)	11 (I/O only)

IMPORTANT:

If you disable all motor nodes with MI976, and do not enable any I/O nodes with MI975, then after saving these values to flash memory, and resetting the Station, you will be able to communicate with the Station only through Node 15. If there are any other Stations on the ring using the same Master number, you will not be able to talk to this board individually. The only command you can send is a broadcast message like **MS\$\$\$***15** which will reset the card(s) to default, allowing you to talk to it using one of the nodes enabled by SW1.

Motor Node Disable: MI976 permits the disabling of motor (servo) nodes that would otherwise be enabled by the SW1 setting. This permits their use on other devices on the ring. Setting Bit *n* of MI976 to 1 forces the disabling of Node *n*, even if the SW1 setting would normally enable it.

I/O Node Enable: MI975 permits the enabling of I/O nodes in addition to the motor nodes that are automatically enabled by the SW1 setting. This permits the automatic real-time transmission of I/O data between the PMAC and the MACRO Station through dedicated I/O nodes.

Multi-channel Servo Interface Setup

Several MI-variables on the 3U MACRO Station affect the hardware setup of multiple machine interface channels on the Station. Because these variables are not specific to one channel or node, they can be accessed with an **MS{anynode}** command, where **{anynode}** is the number of any active node on the Station that is not active on another Station as well.

Channels 1-4 (1st 4-Axis Board)

There are several variables that affect all of the machine interface channels 1 to 4, which are present on the ACC-2E 4-axis piggyback board with jumper E1 connecting pins 1 and 2, or an ACC-24E2x backplane axis board with switches S1-1 and S1-2 ON.

PWM Frequency: MI900 controls the PWM frequency of Channels 1-4. Its setting is only important if the PWM outputs are used through the PMAC2-style connectors. The equation for the frequency is

$$PWM\ Frequency\ (kHz) = 117,964.8 / [4 * MI900 + 6]$$

Generally MI900 is set to the same value as MI992, which controls the PWM frequency for Channels 9 & 10, and the MaxPhase clock frequency. The PWM frequency set by MI900 *must* be equal to N/2 times the Phase clock frequency set by MI992 and MI997, where N is a positive integer.

Hardware Clock Frequencies: MI903 controls the frequencies of the 4 hardware clock signals for Channels 1-4: the encoder sample SCLK, the pulse-and-direction PFMCLK, the analog output DACCLK, and the analog input ADCCLK. MI903 is a 12-bit value consisting of 4 independent 3-bit parts, each controlling one of the clock frequencies. The equation is

$$MI903 = SCLK\ Divider + 8 * PFMCLK\ Divider + 64 * DACCLK\ Divider + 512 * ADCCLK\ Divider$$

The value of each clock divider can take a value of 0 to 7, and the frequency of each clock signal is

$$Clock\ Frequency = 39.3216\ MHz / [2^{Clock\ Divider}]$$

The default value for MI903 of 2258 is suitable for almost all applications. Refer to the detailed description in the MACRO Station Hardware Reference Manual if you wish to change any of these frequencies.

PWM Deadtime/PFM Pulse Width: MI904 controls both the deadtime for PWM outputs on Channels 1-4 and the pulse width for the PFM pulse-and-direction outputs on Channels 1-4. The equations are

$$PWM\ Deadtime(\mu sec) = 0.135 * MI904$$

$$PFM\ Pulse\ Width\ (\mu sec) = MI904 / PFMCLK\ Freq.\ (MHz)$$

DAC Strobe Word: MI905 controls the DAC strobe signal used to create analog outputs for Channels 1-4. It is a 24-bit word that is shifted out 1 bit per DACCLK cycle, MSB first, starting on the rising edge of the phase clock.

MI905 should be set to the default value of \$7FFF00 for use with the on-board 16-bit DACs that come with the Option A PMAC(1)-style interface on the ACC-2E 4-axis piggyback board, or on an ACC-8A breakout board that attaches to the PMAC2-style connectors on the ACC-2E. MI905 should be set to \$7FFFC0 for use with the 18-bit DACs on the ACC-8E PMAC2-style breakout board that attaches to the PMAC2-style connectors on the ACC-2E, or the ACC-24E2A backplane analog axis-interface/breakout board.

ADC Strobe Word: MI940 controls the ADC strobe signal used to interface to serial A/D converters brought in on Channels 1-4. The default value of \$FFFFFFE is suitable for almost all A/D converter types used with the 3U MACRO Station, either for digital current loop feedback, or for general-purpose use from an ACC-28B or ACC-28E board.

Channels 5-8 (2nd 4-Axis Board)

There are several variables that affect all of the machine interface channels 5 to 8, which are present on the 4-axis piggyback board with jumper E1 connecting pins 2 and 3, or an ACC-24E2x backplane axis board with switches S1-1 and S1-2 OFF.

PWM Frequency: MI906 controls the PWM frequency of Channels 5-8. Its setting is only important if the PWM outputs are used through the PMAC2-style connectors. The equation for the frequency is

$$PWM\ Frequency\ (kHz) = 117,964.8 / [4 * MI906 + 6]$$

Generally MI906 is set to the same value as MI992, which controls the PWM frequency for Channels 9 & 10, and the MaxPhase clock frequency. The PWM frequency set by MI906 *must* be equal to N/2 times the Phase clock frequency set by MI992 and MI997, where N is a positive integer.

Hardware Clock Frequencies: MI907 controls the frequencies of the 4 hardware clock signals for Channels 5-8: the encoder sample SCLK, the pulse-and-direction PFMCLK, the analog output DACCLK, and the analog input ADCCLK. MI907 is a 12-bit value consisting of 4 independent 3-bit parts, each controlling one of the clock frequencies. The equation is

$$MI907 = SCLK\ Divider + 8 * PFMCLK\ Divider + 64 * DACCLK\ Divider \\ + 512 * ADCCLK\ Divider$$

The value of each clock divider can take a value of 0 to 7, and the frequency of each clock signal is

$$Clock\ Frequency = 39.3216\ MHz / [2^{Clock\ Divider}]$$

The default value for MI907 of 2258 is suitable for almost all applications. Refer to the detailed description in the MACRO Station Hardware Reference Manual if you wish to change any of these frequencies.

PWM Deadtime/PFM Pulse Width: MI908 controls both the deadtime for PWM outputs on Channels 5-8 and the pulse width for the PFM pulse-and-direction outputs on Channels 5-8. The equations are

$$PWM \text{ Deadtime } (\mu sec) = 0.135 * MI908$$

$$PFM \text{ Pulse Width } (\mu sec) = MI908 / PFMCLK \text{ Freq. (MHz)}$$

DAC Strobe Word: MI909 controls the DAC strobe signal used to create analog outputs for Channels 1-4. It is a 24-bit word that is shifted out 1 bit per DACCLK cycle, MSB first, starting on the rising edge of the phase clock.

MI909 should be set to the default value of \$7FFF00 for use with the on-board 16-bit DACs that come with the Option A PMAC(1)-style interface on the ACC-2E 4-axis piggyback board, or on an ACC-8A breakout board that attaches to the PMAC2-style connectors on the ACC-2E. MI909 should be set to \$7FFFC0 for use with the 18-bit DACs on the ACC-8E PMAC2-style breakout board that attaches to the PMAC2-style connectors on the ACC-2E, or the ACC-24E2A backplane analog axis-interface/breakout board.

ADC Strobe Word: MI941 controls the ADC strobe signal used to interface to serial A/D converters brought in on Channels 1-4. The default value of \$FFFFFFE is suitable for almost all A/D converter types used with the 3U MACRO Station, either for digital current loop feedback, or for general-purpose use from an ACC-28B.

Channels 9-10 (2-Axis Board)

There are several variables that affect all of the machine interface channels 9 and 10, which are present on the 2-axis piggyback board.

PWM Frequency: MI992 controls the PWM frequency of Channels 9 & 10, as well as the “MaxPhase” clock frequency from which the phase clock frequency for the entire MACRO Station is derived (see above). The equation is:

$$PWM \text{ Frequency (kHz)} = 117,964.8 / [4 * MI992 + 6]$$

The MaxPhase frequency is exactly twice the PWM 9-10 frequency.

Hardware Clock Frequencies: MI993 controls the frequencies of the 4 hardware clock signals for Channels 9 & 10: the encoder sample SCLK, the pulse-and-direction PFMCLK, the analog output DACCLK, and the analog input ADCCLK. MI993 is a 12-bit value consisting of 4 independent 3-bit parts, each controlling one of the clock frequencies. The equation is

$$MI993 = SCLK \text{ Divider} + 8 * PFMCLK \text{ Divider} + 64 * DACCLK \text{ Divider} \\ + 512 * ADCCLK \text{ Divider}$$

The value of each clock divider can take a value of 0 to 7, and the frequency of each clock signal is

$$Clock \text{ Frequency} = 39.3216 \text{ MHz} / [2^{Clock \text{ Divider}}]$$

The default value for MI993 of 2258 is suitable for almost all applications. Refer to the detailed description in the MACRO Station Hardware Reference Manual if you wish to change any of these frequencies.

PWM Deadtime/PFM Pulse Width: MI994 controls both the deadtime for PWM outputs on Channels 9 & 10 and the pulse width for the PFM pulse-and-direction outputs on Channels 9 & 10. The equations are

$$PWM\ Deadtime\ (\mu sec) = 0.135 * MI994$$

$$PFM\ Pulse\ Width\ (\mu sec) = MI994 / PFMCLK\ Freq.\ (MHz)$$

DAC Strobe Word: MI999 controls the DAC strobe signal used to create analog outputs for Channels 9 & 10. It is a 24-bit word that is shifted out 1 bit per DACCLK cycle, MSB first, starting on the rising edge of the phase clock.

MI999 should be set to the default value of \$7FFF00 for use with the on-board 16-bit DACs that come with the Option A PMAC(1)-style interface on the ACC-1E 2-axis piggyback board, or on an ACC-8A breakout board that attaches to the PMAC2-style connector on the ACC-1E. MI999 should be set to \$7FFFC0 for use with the 18-bit DACs on the ACC-8E PMAC2-style breakout board that attaches to the PMAC2-style connector on the ACC-1E.

ADC Strobe Word: MI942 controls the ADC strobe signal used to interface to serial A/D converters brought in on Channels 9 & 10. The default value of \$FFFFFFE is suitable for almost all A/D converter types used with the 3U MACRO Station, either for digital current loop feedback, or for general-purpose use from an ACC-28B.

Single-Channel Servo Interface Channel Setup

The hardware of the machine interface channels on the 3U MACRO Station can be configured in software to interface to many different types of devices. This configuration is done by setting Station MI-variables that are specific to the MACRO node that is mapped to the machine interface channel by the setting of the SW1 rotary switch on the Station. Each of these nodes has its own set of MI-variables in the MI910-MI930 range for this hardware setup of the machine interface channel mapped to the node.

These MI-variables are set by the **MS{node},MIxxx** (xxx=910 to 939) command from PMAC, where **{node}** must represent the number of the specific MACRO node, not the number of the any active node on the station, as for all of the other Station MI-variables.

The following table shows the physical location of each machine interface channel that could be on a 3U MACRO Station:

Machine Interface Channel #	Which Stack Axis Board Used	Which Backplane Axis Board Used*	Location On Board
1	ACC-2E w/ E1 1-2	ACC-24E2x w/ S1-1,2 ON	1 st channel
2	ACC-2E w/ E1 1-2	ACC-24E2x w/ S1-1,2 ON	2 nd channel
3	ACC-2E w/ E1 1-2	ACC-24E2x w/ S1-1,2 ON	3 rd channel
4	ACC-2E w/ E1 1-2	ACC-24E2x w/ S1-1,2 ON	4 th channel
5	ACC-2E w/ E1 2-3	ACC-24E2x w/ S1-1,2 OFF	1 st channel
6	ACC-2E w/ E1 2-3	ACC-24E2x w/ S1-1,2 OFF	2 nd channel
7	ACC-2E w/ E1 2-3	ACC-24E2x w/ S1-1,2 OFF	3 rd channel
8	ACC-2E w/ E1 2-3	ACC-24E2x w/ S1-1,2 OFF	4 th channel
9	ACC-1E	--	1 st channel
10	ACC-1E	--	2 nd channel

* ACC-51E encoder interpolator boards can be used here as well as ACC-24E2x boards.

The next table shows which node each machine interface channel is mapped to as a function of the SW1 rotary switch setting:

M.I.C. #	Node for SW1 =0	Node for SW1 =1	Node for SW1 =2	Node for SW1 =3	Node for SW1 =4	Node for SW1 =5	Node for SW1 =6	Node for SW1 =7	Node for SW1 =8	Node for SW1 =9	Node for SW1 =A	Node for SW1 =B	Node for SW1 =C	Node for SW1 =F
1	0	8	0	4*	8	12*	0	0	-	-	-	-	0	-
2	1	9	1	5* ₋	9	13*	1	1	-	-	-	-	1	-
3	4	12	-	4**	-	12**	4	4	-	-	-	-	4	-
4	5	13	-	5**	-	13**	5	5	-	-	-	-	5	-
5	-	-	-	-	-	-	8	8	-	-	-	-	-	-
6	-	-	-	-	-	-	9	9	-	-	-	-	-	-
7	-	-	-	-	-	-	-	12	-	-	-	-	-	-
8	-	-	-	-	-	-	-	13	-	-	-	-	-	-
9	-	-	-	-	-	-	-	-	0	4	8	12	8	-
10	-	-	-	-	-	-	-	-	1	5	9	13	9	-

*Backplane boards only (firmware revisions V1.115 and newer)
 ** Stack boards only (firmware revisions V1.115 and newer); all boards (V1.114 and older)

In many systems, this will result in the Machine Interface Channel number on the MACRO Station matching the Motor Number on the PMAC, even though the data is passed through a MACRO node with a different number.

Encoder Decode: MI910 for the node determines how the encoder signal input is decoded. This is commonly set to 3 or 7 for ‘x4’ quadrature decode, 8 for internal pulse-and-direction decode in the case of stepper outputs, or 12 for MLDT decode.

Command Output Format: MI916 for the node determines the format of the output signals from the channel. This is set to 0 for PWM format on A, B, and C outputs, or to 3 for DAC format on A and B outputs (for velocity-mode, torque-mode, or sine-wave drives), and pulse-and-direction on the C output (for stepper drives or for MLDT excitation).

Position Capture Control: MI912 and MI913 for the node determine which edges of which signals cause a hardware capture of the encoder position for the channel. This capture function is used for very accurate homing, registration, and probing. MI912 is commonly set to 1 for capture on a high index-channel input, 2 for a high flag input, or 3 for both a high index and high flag. MI913 is most commonly set to 0 to select the home signal as the flag capture input.

Other Variables: Refer to the 3U MACRO Station Software Reference for details on the other variables, as well as for more details on the variables explained above.

Station Encoder Conversion Table Setup

The 3U MACRO Station has its own “Encoder Conversion Table” (ECT) that permits pre-processing of feedback data before it is transmitted back to the PMAC controller. This can simplify the transmission and reduce the amount of data to be transmitted.

Note:

The PMAC has its own Encoder Conversion Table that has much the same capabilities as that of the MACRO Station. However, when PMAC is getting its data from the MACRO Station, the PMAC’s table simply uses the “parallel data” format to copy the feedback data from the MACRO node. Refer to the *PMAC2 Software Setup for MACRO Station* section, above.

The ECT on the MACRO Station has a series of “entries” in 32 “lines”. Each “line” occupies one double word of MACRO Station memory. The Y-word has set-up information; the X-word has result information.

Each line’s Y-word has a MACRO Station MI-variable assigned to it, so the set-up can be done by setting MI-variable values. The set-up word for the first line of the table is assigned MI120; the set-up word for the second line for the second line is assigned MI121, and so on, to the 32nd line, whose set-up word is assigned MI151.

An “entry” in the table can occupy 1, 2, or 3 lines, which means that 1, 2, or 3 MI-variables are used to define the set-up words for the entry. If the entry occupies more than 1 line, the final result of the entry is in the last (highest-numbered address) X-word of the entry, matching the last (highest-numbered) set-up MI-variable for the entry. Other X-words in the entry contain intermediate results.

The following table shows the relationship between ECT line numbers, MI-variable numbers, and result addresses:

Table Line #	Set-up MI-Variable	Result Address	Table Line #	Set-up MI-Variable	Result Address
1	MI120	X:\$0020	17	MI136	X:\$0030
2	MI121	X:\$0021	18	MI137	X:\$0031
3	MI122	X:\$0022	19	MI138	X:\$0032
4	MI123	X:\$0023	20	MI139	X:\$0033
5	MI124	X:\$0024	21	MI140	X:\$0034
6	MI125	X:\$0025	22	MI141	X:\$0035
7	MI126	X:\$0026	23	MI142	X:\$0036
8	MI127	X:\$0027	24	MI143	X:\$0037
9	MI128	X:\$0028	25	MI144	X:\$0038
10	MI129	X:\$0029	26	MI145	X:\$0039
11	MI130	X:\$002A	27	MI146	X:\$003A
12	MI131	X:\$002B	28	MI147	X:\$003B
13	MI132	X:\$002C	29	MI148	X:\$003C
14	MI133	X:\$002D	30	MI149	X:\$003D
15	MI134	X:\$002E	31	MI150	X:\$003E
16	MI135	X:\$002F	32	MI151	X:\$003F

Incremental Digital Encoder Feedback: If an incremental digital quadrature or digital pulse-and-direction encoder is used for feedback, the \$00 conversion method is typically used for the timer-based 1/T extension of incremental encoders.

The following table shows the conversion table MI-variable values for this type of feedback with channels in the MACRO Stack configuration:

Encoder #	Which Stack Axis Board Used	Location On Board	Conversion Table MI-variable Value
Encoder 1	ACC-2E w/ E1 1-2	1 st channel	\$00C000
Encoder 2	ACC-2E w/ E1 1-2	2 nd channel	\$00C008
Encoder 3	ACC-2E w/ E1 1-2	3 rd channel	\$00C010
Encoder 4	ACC-2E w/ E1 1-2	4 th channel	\$00C018
Encoder 5	ACC-2E w/ E1 2-3	1 st channel	\$00C020
Encoder 6	ACC-2E w/ E1 2-3	2 nd channel	\$00C028
Encoder 7	ACC-2E w/ E1 2-3	3 rd channel	\$00C030
Encoder 8	ACC-2E w/ E1 2-3	4 th channel	\$00C038
Encoder 9	ACC-1E	1 st channel	\$00C090
Encoder 10	ACC-1E	2 nd channel	\$00C098

The following table shows the conversion table MI-variable values for this type of feedback with channels in the UMAC MACRO “pack” configuration:

Encoder #	Which Backplane Axis Board Used	Location On Board	Conversion Table MI-variable Value
Encoder 1	ACC-24E2x w/ S1-1,2 ON	1 st channel	\$00C040
Encoder 2	ACC-24E2x w/ S1-1,2 ON	2 nd channel	\$00C048
Encoder 3	ACC-24E2x w/ S1-1,2 ON	3 rd channel	\$00C050
Encoder 4	ACC-24E2x w/ S1-1,2 ON	4 th channel	\$00C058
Encoder 5	ACC-24E2x w/ S1-1,2 OFF	1 st channel	\$00C060
Encoder 6	ACC-24E2x w/ S1-1,2 OFF	2 nd channel	\$00C068
Encoder 7	ACC-24E2x w/ S1-1,2 OFF	3 rd channel	\$00C070
Encoder 8	ACC-24E2x w/ S1-1,2 OFF	4 th channel	\$00C078

If it is desired not to use the 1/T extension of the encoder value, the first hex digit of the MI-variable value should be changed from ‘0’ to ‘C’. This setting is recommended when using the simulated feedback from a pulse-and-direction output.

Analog Encoder Feedback: If an analog “sine-wave” encoder is used for servo feedback processed through an external ACC-8D Opt 8 analog encoder interpolator board or 3U-format ACC-8DE or 8FE breakout board (with on-board interpolator option), and brought into a “stack” axis-interface board, the \$80 conversion method is used for parallel sub-count extension of incremental encoders, yielding 128 or 256 states per encoder line.

The following table shows the conversion table MI-variable values for this type of feedback:

Encoder #	Which Stack Axis Board Used	Location On Board	Conversion Table MI-variable Value
Encoder 1	ACC-2E w/ E1 1-2	1 st channel	\$80C000
Encoder 2	ACC-2E w/ E1 1-2	2 nd channel	\$80C008
Encoder 3	ACC-2E w/ E1 1-2	3 rd channel	\$80C010
Encoder 4	ACC-2E w/ E1 1-2	4 th channel	\$80C018
Encoder 5	ACC-2E w/ E1 2-3	1 st channel	\$80C020
Encoder 6	ACC-2E w/ E1 2-3	2 nd channel	\$80C028
Encoder 7	ACC-2E w/ E1 2-3	3 rd channel	\$80C030
Encoder 8	ACC-2E w/ E1 2-3	4 th channel	\$80C038
Encoder 9	ACC-1E	1 st channel	\$80C090
Encoder 10	ACC-1E	2 nd channel	\$80C098

Presently there are no reasonable ways of bringing this style of interpolator through a backplane axis-interface board.

If an analog “sine-wave” encoder is processed through an ACC-51E high-resolution backplane interpolator board, the \$F0 conversion method is used, yielding 4096 states per encoder line. This entry is a three-line entry.

The first line specifies the address of the encoder counter. The following table shows the conversion table MI-variables for the first line for this type of feedback:

Encoder #	Which Backplane Axis Board Used	Location On Board	Conversion Table MI-variable Value
Encoder 1	ACC-51E w/ S1-1,2 ON	1 st channel	\$F0C040
Encoder 2	ACC-51E w/ S1-1,2 ON	2 nd channel	\$F0C048
Encoder 3	ACC-51E w/ S1-1,2 ON	3 rd channel	\$F0C050
Encoder 4	ACC-51E w/ S1-1,2 ON	4 th channel	\$F0C058
Encoder 5	ACC-51E w/ S1-1,2 OFF	1 st channel	\$F0C060
Encoder 6	ACC-51E w/ S1-1,2 OFF	2 nd channel	\$F0C068
Encoder 7	ACC-51E w/ S1-1,2 OFF	3 rd channel	\$F0C070
Encoder 8	ACC-51E w/ S1-1,2 OFF	4 th channel	\$F0C078

The second line specifies the address of the A/D converters used. The following table shows the conversion table MI-variables for the second line for this type of feedback:

Encoder #	Which Backplane Axis Board Used	Location On Board	Conversion Table MI-variable Value
Encoder 1	ACC-51E w/ S1-1,2 ON	1 st channel	\$00C045
Encoder 2	ACC-51E w/ S1-1,2 ON	2 nd channel	\$00C04D
Encoder 3	ACC-51E w/ S1-1,2 ON	3 rd channel	\$00C055
Encoder 4	ACC-51E w/ S1-1,2 ON	4 th channel	\$00C05D
Encoder 5	ACC-51E w/ S1-1,2 OFF	1 st channel	\$00C065
Encoder 6	ACC-51E w/ S1-1,2 OFF	2 nd channel	\$00C06D
Encoder 7	ACC-51E w/ S1-1,2 OFF	3 rd channel	\$00C075
Encoder 8	ACC-51E w/ S1-1,2 OFF	4 th channel	\$00C07D

The third line contains a bias term that is added to both A/D converter readings before the arctangent value is calculated. It is used as a 24-bit value, with the used portion of the A/D converter readings being in the upper 12 bits. For example, if the cycle's average reading from the A/D converters were -5 LSBs of the 12-bit value, this line would be set to $+5 \times 2^{12}$, or 20,480.

Resolver Feedback: If a resolver is used for servo feedback processed through an ACC-8D Opt 7 R/D Converter board, the feedback comes into the 3U MACRO Station as digital quadrature, and is processed the same as a true incremental digital encoder (see above).

MLDT Feedback: If a magnetostrictive linear displacement transducer (MLDT) is used for feedback with the 3U MACRO Station providing the excitation pulse and measuring the time until it receives the echo pulse using its encoder timer circuitry, then the \$30 parallel feedback conversion method is used, reading the encoder's timer register as the position value.

This conversion method uses three lines (MI-variables) of the conversion table. The first MI-variable contains the method and address. The following table shows the conversion table MI-variable values for the first MI-variable of the entry for this type of feedback into "stack" axis boards:

Encoder #	Which Stack Axis Board Used	Location On Board	Conversion Table MI-variable Value
Encoder 1	ACC-2E w/ E1 1-2	1 st channel	\$30C000
Encoder 2	ACC-2E w/ E1 1-2	2 nd channel	\$30C008
Encoder 3	ACC-2E w/ E1 1-2	3 rd channel	\$30C010
Encoder 4	ACC-2E w/ E1 1-2	4 th channel	\$30C018
Encoder 5	ACC-2E w/ E1 2-3	1 st channel	\$30C020
Encoder 6	ACC-2E w/ E1 2-3	2 nd channel	\$30C028
Encoder 7	ACC-2E w/ E1 2-3	3 rd channel	\$30C030
Encoder 8	ACC-2E w/ E1 2-3	4 th channel	\$30C038
Encoder 9	ACC-1E	1 st channel	\$30C090
Encoder 10	ACC-1E	2 nd channel	\$30C098

The following table shows the first conversion table MI-variable values for this type of feedback with channels in the UMAC MACRO "pack" configuration:

Encoder #	Which Backplane Axis Board Used*	Location On Board	Conversion Table MI-variable Value
Encoder 1	ACC-24E2x w/ S1-1,2 ON	1 st channel	\$30C040
Encoder 2	ACC-24E2x w/ S1-1,2 ON	2 nd channel	\$30C048
Encoder 3	ACC-24E2x w/ S1-1,2 ON	3 rd channel	\$30C050
Encoder 4	ACC-24E2x w/ S1-1,2 ON	4 th channel	\$30C058
Encoder 5	ACC-24E2x w/ S1-1,2 OFF	1 st channel	\$30C060
Encoder 6	ACC-24E2x w/ S1-1,2 OFF	2 nd channel	\$30C068
Encoder 7	ACC-24E2x w/ S1-1,2 OFF	3 rd channel	\$30C070
Encoder 8	ACC-24E2x w/ S1-1,2 OFF	4 th channel	\$30C078

The second line of the entry contains a "bits used" mask, a 24-bit value that contains a 1 in each bit that is to be used from the register. In this type of feedback, all 24 bits of the source register can be used, so this line (MI-variable) can be \$FFFFFF.

The third line of the entry contains the maximum change in the input value that the table will let through in one ring cycle. This provides a filter that is a protection against missing or added echo pulses. This value should be set to a value slightly greater than the maximum true velocity

expected. The units are bits of the timer per ring cycle, where one bit of the timer represents 0.0009 inches or 0.024 mm at the 120 MHz timer frequency.

12-Bit A/D Converter Feedback: If an analog input processed through the 12-bit A/D converters on-board the ACC-1E or ACC-6E stack A/D boards, or the ACC-36E or ACC-59E backplane A/D boards, is used for servo feedback, then the \$20 parallel feedback format is used.

The actual ADC inputs are all actually read through 3U MACRO Station I/O register in a multiplexed format, but Station firmware automatically de-multiplexes them into separate internal memory registers at Y:\$0200 to Y:\$0207 if Station variable MI987 has been set to 1. Station MI-variable MI989 specifies the address of the I/O register where the multiplexed A/D converters actually reside. It is the de-multiplexed data in the internal memory registers that the conversion table will read.

The first line of the entry contains the \$20 method and the source address. The second line contains the “bits used” mask word, which is a 24-bit value containing a ‘1’ for every bit of the source register to be used. The first 8 analog inputs occupy the low 12 bits of the 24-bit word, so their mask word is \$000FFF. The second 8 analog inputs occupy the high 12 bits, so their mask word is \$FFF000.

The following table shows the conversion table MI-variable values for the first and second lines (MI-variables) of these entries:

Analog Input Pin	Entry 1 st MI-Var. Value	Entry 2 nd MI-Var. Value	Analog Input Pin	Entry 1 st MI-Var. Value	Entry 2 nd MI-Var. Value
ANAI00	\$200200	\$000FFF	ANAI08	\$200200	\$FFF000
ANAI01	\$200201	\$000FFF	ANAI09	\$200201	\$FFF000
ANAI02	\$200202	\$000FFF	ANAI10	\$200202	\$FFF000
ANAI03	\$200203	\$000FFF	ANAI11	\$200203	\$FFF000
ANAI04	\$200204	\$000FFF	ANAI12	\$200204	\$FFF000
ANAI05	\$200205	\$000FFF	ANAI13	\$200205	\$FFF000
ANAI06	\$200206	\$000FFF	ANAI14	\$200206	\$FFF000
ANAI07	\$200207	\$000FFF	ANAI15	\$200207	\$FFF000

If the \$30 “filtered parallel” method is used instead of \$20, it is a 3-line entry instead of a 2-line entry. The third line of the entry contains the maximum change in the input value that the table will let through in one ring cycle. This provides a filter that is a protection against noise. This value should be set to a value slightly greater than the maximum true velocity expected. The units are bits of the ADC per ring cycle.

Note:

Station Variable MI988 controls whether the A/D converters are expecting inputs in the -2.5V to +2.5V range, or in the 0 to +5V range.

ACC-28B/E 16-Bit A/D Converter Feedback: If analog feedback processed through an ACC-28B 16-bit A/D converter and brought into the 3U MACRO Station through an ACC-8T and a PMAC2-style connector on a “stack” axis board is used for servo feedback, the \$18 conversion method is used for unsigned 16-bit A/D feedback. The following table shows the conversion table MI-variable values for this type of feedback:

ADC #	Which Board Used	Which CMS Connector Used	Location On ACC-28B	Conversion Table MI-variable Value
ADC 1A	ACC-2E w/ E1 1-2	J4	1 st channel	\$18C005
ADC 1B	ACC-2E w/ E1 1-2	J4	2 nd channel	\$18C006
ADC 2A	ACC-2E w/ E1 1-2	J4	3 rd channel	\$18C00D
ADC 2B	ACC-2E w/ E1 1-2	J4	4 th channel	\$18C00E
ADC 3A	ACC-2E w/ E1 1-2	J5	1 st channel	\$18C015
ADC 3B	ACC-2E w/ E1 1-2	J5	2 nd channel	\$18C016
ADC 4A	ACC-2E w/ E1 1-2	J5	3 rd channel	\$18C01D
ADC 4B	ACC-2E w/ E1 1-2	J5	4 th channel	\$18C01E
ADC 5A	ACC-2E w/ E1 2-3	J4	1 st channel	\$18C025
ADC 5B	ACC-2E w/ E1 2-3	J4	2 nd channel	\$18C026
ADC 6A	ACC-2E w/ E1 2-3	J4	3 rd channel	\$18C02D
ADC 6B	ACC-2E w/ E1 2-3	J4	4 th channel	\$18C02E
ADC 7A	ACC-2E w/ E1 2-3	J5	1 st channel	\$18C035
ADC 7B	ACC-2E w/ E1 2-3	J5	2 nd channel	\$18C036
ADC 8A	ACC-2E w/ E1 2-3	J5	3 rd channel	\$18C03D
ADC 8B	ACC-2E w/ E1 2-3	J5	4 th channel	\$18C03E
ADC 9A	ACC-1E	J4	1 st channel	\$18C095
ADC 9B	ACC-1E	J4	2 nd channel	\$18C096
ADC 10A	ACC-1E	J4	3 rd channel	\$18C09D
ADC 10B	ACC-1E	J4	4 th channel	\$18C09E

This method can also be used for the 16-bit ADCs on an ACC-28E backplane board. The following table shows the possible entry settings, depending on the settings of DIP switch S1 on the board.

S1-1	S1-2	ADC1	ADC2	ADC3	ADC4
ON	ON	\$18FFE0	\$18FFE1	\$18FFE2	\$18FFE3
OFF	ON	\$18FFE8	\$18FFE9	\$18FFEA	\$18FFEB
ON	OFF	\$18FFF0	\$18FFF1	\$18FFF2	\$18FFF3
OFF	OFF	\$18B8C0*	\$18B8C1*	\$18B8C2*	\$18B8C3*

* Requires Station firmware revision V1.115 or newer to use this setting.

If it is desired to integrate the A/D value before computing the result, the first hex digit of the entry should be changed from a “1” to a “5”. In this case, there is a second line to the entry, which specifies a “bias” value that is subtracted from the A/D reading before the integration. This bias is expressed as a 24-bit value, with the upper 16 bits matching the actual data from the A/D converter. For example, if zero voltage into the A/D converter produced a reading of 3 LSBs of the converter, the bias term should be set to 3×2^8 , or 768.

ACC-3E/14E Parallel Feedback: If parallel data brought in through one of the connectors on an ACC-3E 144-I/O stack board, or an ACC-14E I/O backplane board, is used for servo feedback, the \$3x conversion method is used for parallel feedback.

Each connector can bring in up to 24 bits of input, mapped as a byte in each of three consecutive words of memory, with the least significant byte mapped into the low address. The least

significant bit of the input should be connected to the lowest-numbered I/O point on the connector. The J4 and J5 connectors map into the low byte of these words; the J6 and J7 connectors map into the middle byte; and the J8 and J9 connectors map into the high byte.

If the ‘x’ digit in the method is ‘4’, the low byte of the three words is used; if ‘x’ is ‘5’, the middle byte is used; if ‘x’ is ‘6’, the high byte is used. The address specified is the low address of the three words used.

The following table shows the conversion table MI-variable values for the first line of the entry for this type of feedback through an ACC-3E stack board:

Address Jumper Used	Connector Used	Entry 1 st MI-Var. Value	Address Jumper Used	Connector Used	Entry 1 st MI-Var. Value
E1	J4	\$34FFC0	E3	J4	\$34FFD0
E1	J5	\$34FFC3	E3	J5	\$34FFD3
E1	J6	\$35FFC0	E3	J6	\$35FFD0
E1	J7	\$35FFC3	E3	J7	\$35FFD3
E1	J8	\$36FFC0	E3	J8	\$36FFD0
E1	J9	\$36FFC3	E3	J9	\$36FFD3
E2	J4	\$34FFC8	E4	J4	\$34FFD8
E2	J5	\$34FFCB	E4	J5	\$34FFDB
E2	J6	\$35FFC8	E4	J6	\$35FFD8
E2	J7	\$35FFCB	E4	J7	\$35FFDB
E2	J8	\$36FFC8	E4	J8	\$36FFD8
E2	J9	\$36FFCB	E4	J9	\$36FFDB

The following table shows the conversion table MI-variable values for the first line of the entry for this type of feedback through an ACC-14E backplane board:

S1-1	S1-2	Connector Used	Entry 1 st MI-Var. Value
ON	ON	Top	\$34FFE0
ON	ON	Bottom	\$34FFE3
OFF	ON	Top	\$34FFE8
OFF	ON	Bottom	\$34FFEB
ON	OFF	Top	\$34FFF0
ON	OFF	Bottom	\$34FFF3
OFF	OFF	Top	\$34B8C0*
OFF	OFF	Bottom	\$34B8C3*

* Requires Station firmware revision V1.115 or newer to use this setting.

Amplifier Fault Enable and Polarity Control

MI17 and MI18 permit the user to define whether and how the amplifier-fault inputs to the station are used. Each is an 8-bit variable, with one bit for each servo node. The following table shows which bit matches which servo node:

Node Number ‘n’	0	1	4	5	8	9	12 (C)	13 (D)
MI17, MI18 Bit #	0	1	2	3	4	5	6	7

The matching of servo nodes to hardware channel numbers is determined by the setting of rotary switch SW1.

MI17 Amplifier Fault Disable Control: MI17 permits the disabling of amplifier fault inputs. If a bit of MI17 is set to the default of 0, the amplifier fault input for the channel connected to that node is enabled – causing a fault input to disable the outputs on that channel and to notify the

PMAC over the MACRO ring that an amplifier fault has occurred. If the bit is set to 1, the amplifier fault input is not used automatically – no action is taken if the fault input changes.

MI18 Amplifier Fault Polarity Control: MI18 permits the user to determine the polarity of the amplifier fault inputs. If a bit of MI18 is set to the default of 0, the amplifier fault input for the channel connected to that node is considered “low-true”, which means that a logical 0 read on this channel’s fault bit is considered a fault condition, regardless of the input voltage to create this state. If the bit is set to 1, the amplifier fault input is considered “high-true”, which means that a logical 1 read on this channel’s fault bit is considered a fault condition.

On Delta Tau MACRO Station accessories, the fault bit is typically brought in through an “AC Opto” component, for which current flowing in either direction creates a logical 0. In the default setup of MI18, this state is considered an amplifier fault. Note that if nothing is connected to such an amplifier fault input, the matching bit of MI18 must be set to 0 in order for the Station to consider the channel not to be in a fault condition.

Bit 23 of Ix25 on a PMAC2, or of Ixx24 on a Turbo PMAC2, for the motor assigned to this node, which control the amplifier fault polarity at the controller, must be the same value as the matching bit of MI18. The Station will pass back the amplifier fault bit to the PMAC2 in the same polarity it receives it, and any MACRO fault passed back using this same bit will be of the same polarity.

Servo Address Variable Setup

There are a few MI-variables for each motor node. Because the motor nodes are not consecutively numbered (0, 1, 4, 5, 8, 9, 12, 13), these variables specify the node not by its number but by its order (e.g. Node 0 is the 1st motor node). The following table provides an easy reference:

Node Number ‘n’	0	1	4	5	8	9	12 (C)	13 (D)
Node Order ‘x’	1	2	3	4	5	6	7	8

The last digit of the MI-variable number is represented generally by ‘x’, where ‘x’ represents the order of the motor node – the ‘xth’ motor node. In most cases ‘x’ will also represent the Machine Interface Channel used on the 3U MACRO Station, and the Motor number on PMAC.

MI10x Position Feedback Address: After the initial processing of the feedback in the Station’s encoder conversion table, the data is copied to the feedback register of a motor node. Station MI-variable MI10x for the ‘xth’ motor node used contains the address of the register, usually one in the conversion table, from which the feedback data is copied into the position feedback register of the node. Because the conversion table occupies registers \$0020 to \$003F in the Station, the values of the MI10x variables typically contain address values in this range.

MI11x Power-On Position Feedback Address: If absolute power-on position is desired for either commutation phase referencing or complete position referencing, MI11x for the xth motor node on the 3U MACRO Station must be set to a value greater than zero.

MI16x Power-On MLDT Excitation Value: If a magnetostrictive linear displacement transducer (MLDT) is to receive its excitation pulses from the 3U MACRO Station, MI16x is used for the xth motor node to set the frequency of the excitation immediately upon power-up or reset so the absolute power-on position of the sensor can be read. If MI16x is greater than 0, this value is copied into the ‘C’ output register for the machine interface channel corresponding to the xth motor node (as determined by the SW1 setting) as part of the reset function of the Station. Thereafter, only ‘A’ and ‘B’ command values are copied from the MACRO node command registers to the machine interface channel registers.

The period between output pulses should be slightly longer than the longest delay in receiving the “echo pulse”. This delay can be computed by multiplying the length of the MLDT by the speed of sound in the MLDT, usually about 2.8 mm/μsec (0.11 in/μsec). With the output period decided, MI16x can be computed according to the formula:

$$MI16x = 16,777,216 / [Output_Period (\mu sec) * PFMCLKfreq (MHz)]$$

For example, to get an output period of 500 μsec (2kHz frequency) with PFMCLK at the default frequency of 9.83 MHz, MI16x can be computed as:

$$MI16x = 16,777,216 / (500 * 9.83) = 3413$$

General-Purpose I/O Setup

The general-purpose I/O (that not directly associated with a motor channel) on the 3U MACRO Station can be set up with just a few Station MI-variables. The basic concept for real-time general-purpose I/O is that of automatic copying of data between the I/O registers and I/O MACRO nodes. Combined with the automatic copying of data between MACRO nodes on the Station and MACRO nodes on the PMAC controlling the Station, we obtain an automatic transfer between the PMAC and the I/O points on the Station

MI975 I/O Node Enable

If the I/O MACRO nodes have not already been enabled as part of the initial setup of the MACRO Station, they can be enabled now with MI975. If switch SW1 on the Station has been set to enable any motor nodes, there are no active MACRO I/O nodes enabled by default. However, setting Bit n of MI975 to 1 enables Node n for I/O transfer over MACRO.

If switch SW1 has been set to E (14) and MI975 has been set to its default value of 0 at the most recent power-up/reset, then no motor nodes are enabled, but I/O Node 11 is enabled by default. This setting simply permits communications to an I/O-only MACRO Station before its configuration is finalized

However, if MI975 is set to a non-zero value on a Station with SW1 set at E (14), then MI975 alone controls which I/O nodes are active. Setting Bit n of MI975 to 1 activates Node n for I/O transfer over MACRO. In this case, Node 11 is not active unless Bit 11 of MI975 is set to 1.

Changes in MI975 only take place at a Station power-up/reset. Therefore to change which I/O nodes on a Station are active, MI975 must be changed, the new value stored to non-volatile flash memory with the **MSSAVE{anynode}** command, then the board reset (usually with the **MS\$\$\${anynode}** command). Note that in determining the final active-node word reported in MI996, the MACRO Station clears bit 15 of MI975 to make sure that node 15 is reserved for auxiliary communications.

MI19 I/O Transfer Period

The general-purpose I/O copying, or transfer, functions on the MACRO Station are enabled by setting MI19 greater than zero. If MI19 is greater than 0, its value specifies the period of the transfer in phase cycles. Typically, this is set to 1, so the transfer is performed every phase cycle. If MI19 is set to 0, none of the transfer variables explained below have any effect.

Bi-directional I/O Transfer Control

Several MI variables on the MACRO Station enable the bi-directional copying of I/O values between MACRO nodes and configurable input/output registers on MACRO Station I/O boards.

Copying from the MACRO node to the I/O register is used for setting outputs; copying from the I/O register to the MACRO node is used for reading inputs. The copying is always done in both directions for all I/O points, even though each I/O point can only be used as an input or an output

at any given time. Only a zero value (output off) should be written to an I/O point that is currently being used as an input.

The following MACRO I/O boards will use these bi-directional-copying variables:

- ACC-3E 48/96/144 I/O Piggyback (Stack) Board
- ACC-4E Isolated 24-Input/24-Output Piggyback (Stack) Board
- ACC-9E Isolated 48-Input Backplane (UMAC) Board
- ACC-10E Isolated 48-Output Backplane (UMAC) Board
- ACC-11E Isolated 24-Input/24-Output Backplane (UMAC) Board
- ACC-12E Isolated 24-Input/24-High-Power-Output Backplane (UMAC) Board
- ACC-14E 48 I/O Backplane (UMAC) Board

The following Station MI-variables perform the bi-directional transfers with these boards:

- **MI69 and MI70:** These variables copy I/O values between 16-bit MACRO node registers (Registers 1, 2, and 3) and accessory-board I/O registers. These are particularly valuable for single I/O boards with 48 I/O points.
- **MI71:** This variable copies I/O values between 24-bit MACRO node registers (Register 0) and accessory-board I/O registers. This is particularly valuable for single I/O boards with 48 I/O points.
- **MI169:** This variable copies 72 I/O values between an entire 72-bit MACRO node and accessory-board I/O registers.
- **MI171, MI172, and MI173:** These variables copy 144 I/O values between a pair of 72-bit MACRO nodes and accessory-board I/O registers. These are valuable for fully configured ACC-3E boards or a set of 3 backplane I/O boards sharing a common base address.

MACRO Node Addressing: In each of these variables, both the address of a MACRO I/O node register and an I/O board base address register must be specified. The following table lists the possible MACRO I/O node register addresses:

I/O Node #	Register 0 X-Address	Register 1 X-Address	Register 2 X-Address	Register 3 X-Address
2	\$C0A0	\$C0A1	\$C0A2	\$C0A3
3	\$C0A4	\$C0A5	\$C0A6	\$C0A7
6	\$C0A8	\$C0A9	\$C0AA	\$C0AB
7	\$C0AC	\$C0AD	\$C0AE	\$C0AF
10	\$C0B0	\$C0B1	\$C0B2	\$C0B3
11	\$C0B4	\$C0B5	\$C0B6	\$C0B7
14*	\$C0B8	\$C0B9	\$C0BA	\$C0BB
*Node 14 may only be used for these I/O transfers if no Type 1 Master/Master auxiliary communications are being performed on the ring between Turbo PMAC2 boards.				

I/O Board Addressing: The 3U-format I/O boards are built around “IOGATE” I/O ASICs. Each IOGATE IC controls 48 I/O points, mapped into the MACRO Station’s addressing scheme as 6 bytes in consecutive registers (Base_address to Base_address+5). The MACRO Station has a 24-bit data bus, so it is possible to have up to 3 IOGATE ICs in the same address space. Many of the I/O boards support this, as do the bi-directional copying variables.

The following table lists the possible base addresses of the ACC-3E and ACC-4E piggyback (Stack) I/O boards:

ACC-3E Address Jumper ON	ACC-4E Address Jumper ON	Board Base Y-Address
E1	E15	\$FFC0
E2	E16	\$FFC8
E3	E17	\$FFD0
E4	E18	\$FFD8

The single IOGATE IC of the ACC-4E is always mapped into the low byte of the addresses it occupies. The ACC-3E may have up to 3 ICs, according to the options installed as listed by the following table:

Option	Byte on Data Bus	I/O Points
A	Low (bits 0 – 7)	I/O00 – I/O47
B	Middle (bits 8 – 15)	I/O48 – I/O95
C	High (bits 16 – 23)	I/O96 – I/O143

The following table lists the possible base addresses of the ACC-9E, 10E, 11E, and 12E backplane (UMAC) I/O boards:

ACC Board Address Jumper ON	Board Base Y-Address
E1	\$FFE0
E2	\$FFE8
E3	\$FFF0
E4	\$B8C0*
*Requires Station firmware revision V1.115 or newer	

The single IOGATE IC on each of these boards may occupy the low, middle, or high byte of the address space, depending on which rows of the E6 matrix are connected by jumpers:

E6A – E6H Rows Connected	Byte on Data Bus
1 & 2	Low (bits 0 – 7)
2 & 3	Middle (bits 8 – 15)
3 & 4	Middle (bits 8 – 15)
4 & 5	High (bits 16 - 23)

The single IOGATE on the ACC-14E board can only occupy the low byte of the address space.

Which of these variables is used in a MACRO Station is dependent on the exact configuration desired.

MI69 and MI70 can copy data between 1, 2, or 3 48-bit IOGATE ICs at the same base address and 1, 2, or 3 sets of 3 16-bit registers in MACRO I/O nodes. The first IOGATE must be in the low byte of the address, the second (if used) must be in the middle byte of this address, and the third (if used) must be in the high byte. The first IOGATE is matched to the 3 16-bit registers in the MACRO I/O node whose address is specified, the second to these registers in the next MACRO I/O node, and third to these registers in the following MACRO I/O node.

MI69, MI70, bi-directional copying action

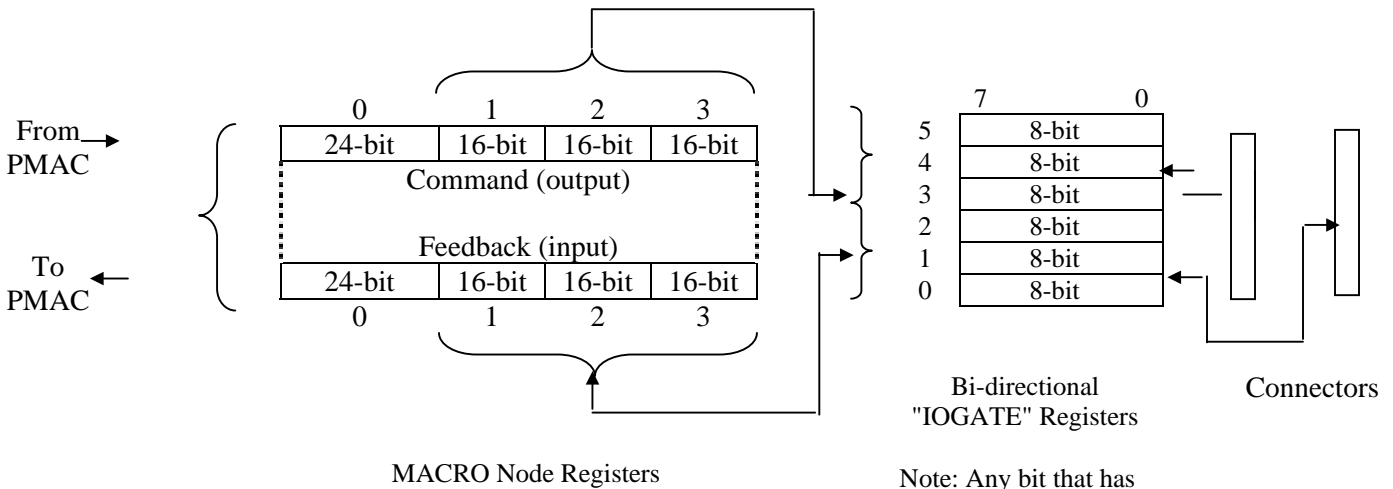

Note: command and feedback registers for a node share addresses. MACRO station read operations access command registers; write operations access feedback registers.

Note: Any bit that has a zero command value written to it (output off) can be used as an input.

MI71 can copy data between 1, 2, or 3 48-bit IOGATE ICs at the same base address and pairs of 24-bit registers in adjacent MACRO I/O nodes. The first IOGATE must be in the low byte of the address, the second (if used) must be in the middle byte of this address, and the third (if used) must be in the high byte. The first IOGATE is matched to the 24-bit register in the MACRO I/O node whose address is specified and the 24-bit register in the next MACRO I/O node, the second IOGATE (if used) is matched to the 24-bit registers in the next pair of MACRO I/O nodes, and the third (if used) is matched to the 24-bit registers in the following pair of MACRO I/O nodes.

MI71, bi-directional copying action

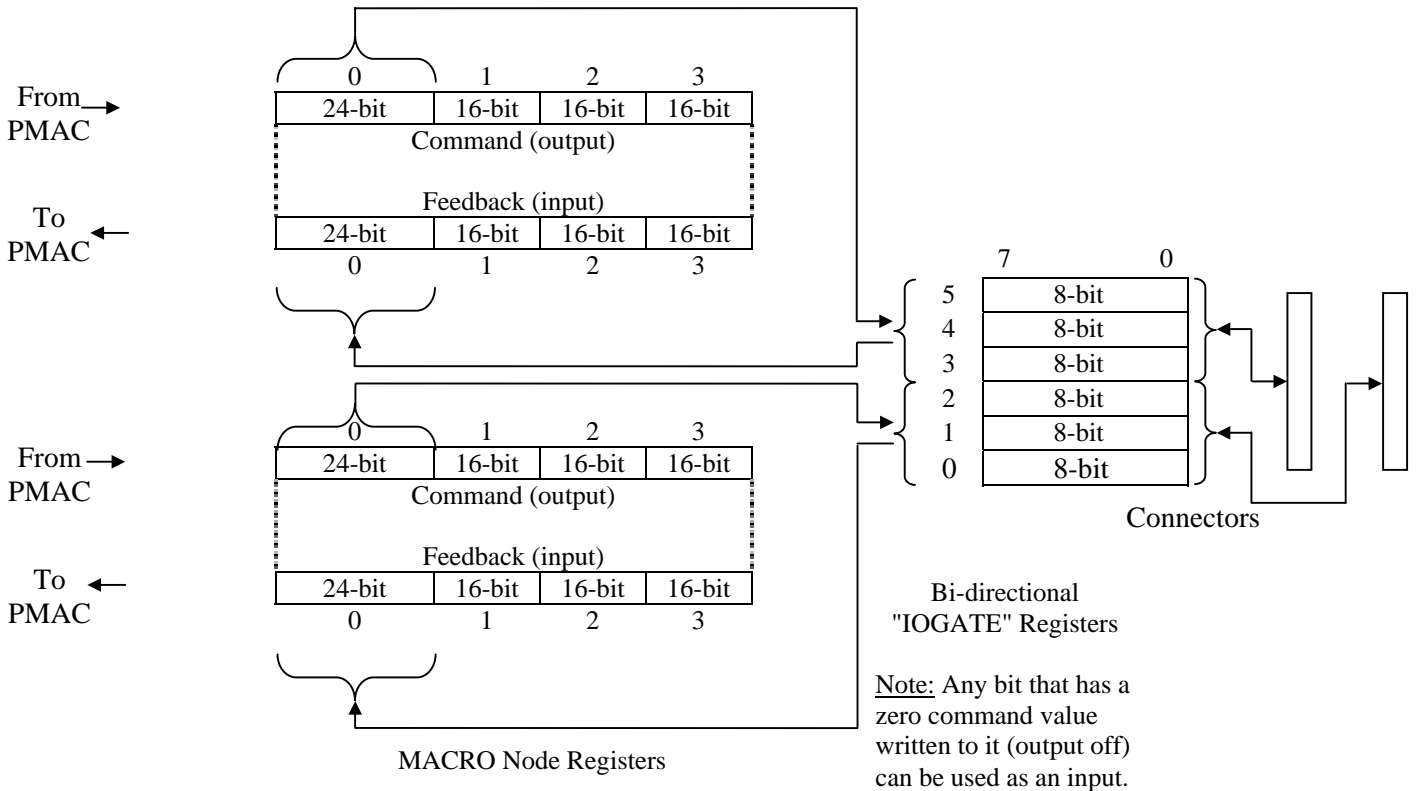

Note: command and feedback registers for a node share addresses. MACRO station read operations access command registers; write operations access feedback registers.

MI169 and MI170 can copy data between 2 48-bit IOGATE ICs (although only using the first half of the second IC) and the full 72 bits of a MACRO I/O node (the three 16-bit registers and the single 24-bit register). The first IOGATE must be in the low byte of the address, the second (if used) must be in the middle byte of this address. The first IOGATE is matched to the 3 16-bit registers in the MACRO I/O node whose address is specified, and the half of the second IOGATE is matched to the 24-bit register.

MI171, MI172, and MI173 can copy data between 3 48-bit IOGATE ICs at the same base address and the full 72 bits of two consecutive MACRO I/O nodes (the three 16-bit registers and the single 24-bit register of each). The first IOGATE must be in the low byte of the address, the second must be in the middle byte of this address, and the third must be in the high byte.

For more details and examples on the setting of these variables, consult the Software Reference manual for UMAC MACRO and the MACRO Stack, and the individual manuals for the I/O accessories.

Uni-directional I/O Transfer Control

MACRO Station variables MI21 through MI68 specify uni-directional copying functions between pairs of MACRO Station registers, usually some kind of I/O register and a MACRO node register. MI20 is a 48-bit mask variable that specifies which of the 48 possible transfers specified

by MI21 through MI68 will actually occur. MI19 controls the frequency at which these transfers occur; it must be greater than 0 for these transfers to occur at all.

MI21 through MI68 are 48-bit variables expressed as 12 hexadecimal digits. Each controls one copying operation from a “source” register to a “destination” register. Each variable consists of four parts:

1. Digits 1 & 2: A code representing what part of the source register is used
2. Digits 3 – 6: The address of the source register in the MACRO Station
3. Digits 7 & 8: A code representing what part of the destination register is used
4. Digits 9 – 12: The address of the destination in the MACRO Station

The most commonly used code values are:

- \$54: Y-register bits 0 – 11 (Lower 12-bit ADC registers)
- \$60: Y-register bits 12 – 23 (Upper 12-bit ADC registers)
- \$6C: Y-register bits 8 – 23 (16-bit MACRO servo node registers, ACC-28 ADCs)
- \$78: Y-register bits 0 – 23 (24-bit MACRO servo node registers)
- \$DC: X-register bits 8 – 23 (16-bit MACRO I/O node registers)
- \$E8: X-register bits 0 – 23 (24-bit MACRO I/O node registers, conversion table results)

A complete list is found in the Software Reference description of these variables.

Addresses of the registers used can be found in many places in the User’s Manual and Software Reference; a complete listing is found in the back of the Software Reference.

Macro Station Position Capture Setup

The position-capture function latches the current encoder position at the time of an external event into a special register. It is executed totally in hardware, without the need for software intervention (although it is set up, and later serviced, in software). This means that the only delays in the capture are the hardware gate delays (negligible in any mechanical system), so this provides an incredibly accurate capture function.

Setting the Trigger Condition

The position capture register can be used both "automatically", as in homing routines where the firmware handles the register directly, and "manually", where the user program(s) must handle the register information. Regardless of the mode, the event that causes the position capture is determined by Encoder I-variables 2 & 3 on the Macro Station (ms0,mi912 and ms0,mi913 for encoder1 at node0). Encoder I-Variable 2 defines what combination of encoder third-channel transition and encoder flag transition triggers the capture (it also allows software trigger). If it says to use a flag, Encoder I-variable 3 determines which flag (almost always set to zero to specify the home flag).

Using for Homing

When using this feature for homing a motor, the motor flag address I-variable (Ix25 for motor x) must point to the proper set of flags (this has to be done anyway to address the limit flags properly). For instance, the default value of I125 for a Turbo Ultralite is \$3440, pointing to the first set of flags (with I70/I72/I74/I76 set up to automatically copy the flags to the Macro Station). Then Encoder/Flag I-variable 2 (e.g. ms0, mi912) and Encoder/Flag I-variable 3 (e.g. ms0, mi913) define the transition within this encoder and flags to cause the position capture. Once these have been set up properly, the homing function will use the position-capture feature automatically.

Using in User Program

If you are using the position-capture function in your own program, these two I-variables still control the capture event. You will access the captured position through a full word Macro Station MI-variable (for node0/channel 1 use ms0,mi921). To enable the manual function of position capture two bits in the PMAC MACRO flag command word must be set. Bit 0 and then Bit 11 or both at the same time must be set. At completion of position capture, these bits should be cleared. Bit 0 is cleared at the beginning of a homing sequence.

NodeCntrlCmd: (Sent by Master - Located in PMAC at Y:\$F70 .. Y:\$F7F and TURBO at: Y:\$3440 .. Y:\$347F / Y-portion of Flag Address)

B00 - * Position Capture (Triggered Event) Enable Flag

B01-07= Not used (On Ring B00-07 for Type 1 protocol = NA and for Type 0 protocol = \$FF).

B08 - Reserved for future ring protocol control

B09 - Reserved for future ring protocol control

B10 - Reserved for future ring protocol control

B11 - * Position Capture (Triggered Event) Enable Flag

B12 - Node Reset command

B13 - This Slave detected a MACRO Ring Break (MRB) & became a Synchronizing Master

B14 - * Real-time Data or Amp. Enable

B15 - When B13 = 1 then B15 = 1 & is a Station Fault.

B16-18 Reserved for future ring protocol control

B19 - Fast User Defined Command Flag (UserCmd1)

B20 - Fast User Defined Command Flag (UserCmd2)

B21 - Fast User Defined Command Flag (UserCmd3)

B22 - Fast User Defined Command Flag (UserCmd4)

B23 - Fast User Defined Command Flag (UserCmd5)

Other information useful is the actual information located at the flag address:

NodeCntrlStatus: (Sent by Slave - Located in gate array except for bits 0-7)

(PMAC at X:\$F70 .. X:\$F7F and TURBO at: X:\$3440 .. X:\$347F)

B0-7 = Not used for Type 1 and \$0 for Type 0 protocol.

B08 - Encoder count error

B09 - Position compare (EQU_n)output

B10 - Position captured-on-gated -index flag.

B11 - * Position Captured (Triggered Event Occurred) Flag.

B12 - A Power On Reset POR has occurred.

B13 - This Node detected a MACRO Ring Break (MRB).

B14 - Amplifier Enabled.

B15 - * Amplifier or Station Node shutdown Fault.

B16 - Home Flag(HMFL_n) Input Value

B17 - * Positive End Limit Flag (PILM_n) Input Value.

B18 - * Negative End Limit Flag (NILM_n) Input Value.

B19 - Fast User Status Flag(UserSatus1) or USER_n Input Value if have PMAC Gate Array

B20 - Fast User Status Flag(UserSatus2) or FlgW_n Input Value if have PMAC Gate Array

B21 - Fast User Status Flag(UserSatus3) or FlgV_n Input Value if have PMAC Gate Array

B22 - Fast User Status Flag(UserSatus4) or FlagU_n Input Value if have PMAC Gate Array

B23 - Fast User Status Flag(UserSatus5) or FlagT_n Input Value if have PMAC Gate Array

* The PMAC firmware supports these bit locations and are required for a PMAC Master.

The BOLD are reserved and defined flag locations.

APPENDIX: MACRO STATION TYPE 1 PROTOCOLS

The 3U MACRO station, as a multi-node station, implements the Type 1 MACRO protocol. In this protocol, all 4 registers in each node are used for real-time communications; Node 15 is used for auxiliary communications for the entire station through the MS auxiliary communications commands..

The Type 1 protocol uses the MACRO node registers for each mode of operation as explained below:

Velocity/Torque Mode

Node Register #	0 (24 bits)	1 (16 bits)	2 (16 bits)	3 (16 bits)
Command	Velocity/Torque Command	(reserved)	(reserved)	Motor Command Flags
Feedback	Position Feedback	(reserved)	(reserved)	Motor Status Flags

Phase Current (“Sinewave”) Mode

Node Register #	0 (24 bits)	1 (16 bits)	2 (16 bits)	3 (16 bits)
Command	Phase A Current Command	Phase B Current Command	(reserved)	Motor Command Flags
Feedback	Position Feedback	(reserved)	(reserved)	Motor Status Flags

Phase Voltage (“Direct PWM”) Mode

Node Register #	0 (24 bits)	1 (16 bits)	2 (16 bits)	3 (16 bits)
Command	Phase A Voltage Command	Phase B Voltage Command	Phase C Voltage Command	Motor Command Flags
Feedback	Position Feedback	Phase A Current Feedback	Phase B Current Feedback	Motor Status Flags

All of the 16-bit registers appear in the top 16 bits of the 24-bit word on both PMAC/PMAC2 and the 3U MACRO Station.